



EM DIVISION

DOCUMENT TITTLE : **SOFTWARE REQUIREMENTS
SPECIFICATION FOR THE AIRBORNE
REAL TIME INSTRUMENTATION
SYSTEM**

DOCUMENT NO. : **EM/000/SRS/DD/003**

REVISION NO. : **2**

ORIGINAL ISSUE DATE : **November , 2000**

PREPARED BY : Imam M. Shofi **DATE** : **November , 2000**
Dept. DLP-FTC

Nugrajanto HS **DATE** : **November , 2000**
Dept. TIS-FTC

CHECKED BY : Ir. Husein Abud **DATE** : **November , 2000**
Dept. DLP-FTC

Ir. Lukman Hakim S **DATE** : **November , 2000**
SBU TES

APPROVED BY : Dr. Ir. Hari Muhammad **DATE** : **November , 2000**
Dept. FEA-FTC



**SOFTWARE REQUIREMENTS
SPECIFICATION
for Airborne Real Time Instrumentation System**

Document No.
EM/000/SRS/DD/003

Revision: 1

REVISION PAGE

REVISION	DESCRIPTION
1	<ul style="list-style-type: none"> • Redefine System overview • Redefine DFD/CFD 0, DFD/CFD 1, DFD/CFD 3, DFD/CFD 4, and remove DFD/CFD 5 • Add requirement to record engineering data, display mixed, and display xplot
2	<ul style="list-style-type: none"> • Redefine System overview • Redefine paragraph 3.5, 3.8, 3.9
3	
4	
5	
6	

Index Date	New 11/02/99	1 09/11/00	2	3	4	5	6
Prepared by	IMS, NHS	IMS, NHS	IMS, NHS				
Checked by	HSN, LHS	HSN, LHS	HSN, LHS				
Approved by	HM	HM	HM				



**SOFTWARE REQUIREMENTS
SPECIFICATION**
for Airborne Real Time Instrumentation System

Document No.
EM/000/SRS/DD/003
Revision: **1**

TABLE OF CONTENTS

1	SCOPE.....	7
1.1	IDENTIFICATION	7
1.2	CSCI OVERVIEW	7
1.3	DOCUMENT OVERVIEW	10
2	APPLICABLE DOCUMENTS.....	11
2.1	INTERNATIONAL DOCUMENTS	11
2.2	THOMSON-CSF DOCUMENTS	11
2.3	IPTN DOCUMENTS.....	11
3	ENGINEERING REQUIREMENTS.....	12
3.1	CSCI EXTERNAL INTERFACES REQUIREMENTS	12
3.2	CSCI CAPABILITY REQUIREMENTS	13
3.2.1	<i>Capability 1: Initiate Program</i>	19
3.2.1.1	Capability 1.1 : Initiate System Configuration	23
3.2.1.2	Capability 1.2 Define Global Parameter.....	23
3.2.1.3	Capability 1.3 Setup Presentation (SRS_REQ_13000).....	23
3.2.1.3.1	Capability 1.3.1 Setup IRIGtime	26
3.2.1.3.2	Capability 1.3.2 Setup DisMod.....	26
3.2.1.3.3	Capability 1.3.3 Setup FramRed.....	27
3.2.1.3.4	Capability 1.3.4 Setup NumSym	27
3.2.1.4	Capability 1.4 Generate PCMLUT (SRS_REQ_14000).....	28
3.2.1.4.1	Capability 1.4.1 Create Parameter Vector.....	31
3.2.1.4.2	Capability 1.4.2 Append System Vector.....	31
3.2.1.4.3	Capability 1.4.3 Append Vector of Multiword Parameter	31
3.2.1.4.4	Capability 1.4.4 Sort Vector	32
3.2.1.4.5	Capability 1.4.5 Compress Vector.....	32
3.2.1.4.6	Capability 1.4.6 Update Parameter Vector	32
3.2.1.5	Capability 1.5 Select Extended Formula.....	33
3.2.1.6	Capability 1.6 Report AC_Config	33
3.2.1.6.1	Capability 1.6.1 Print AC_Config	34
3.2.1.6.2	Capability 1.6.2 Record AC_Config.....	35
3.2.1.7	Capability 1.7 Select Local Parameters	35
3.2.2	<i>Capability 2 : Collect Electrical Data from ACARD</i>	36
3.2.2.1	Capability 2.1 : Find Buffer Location.....	38
3.2.2.2	Capability 2.2 : Find ISRPCM.....	39
3.2.2.3	Capability 2.3 : Store Address Buffer to ISRPCM	39
3.2.2.4	Capability 2.4 : Put Electrical Data to Param	40
3.2.2.5	Capability 2.5 : ArtBuf.com and ISR.PCM.com (non-developmental software).....	40
3.2.3	<i>Capability 3: Translate to Engineering Data (SRS_REQ_30000)</i>	40
3.2.3.1	Capability 3.1 : Get Local Parameter.....	44
3.2.3.2	Capability 3.4 : Convert ARINC	45
3.2.3.3	Capability 3.5 : Calculate Linear	45
3.2.3.4	Capability 3.6 : Calculate Polynom	46
3.2.3.5	Capability 3.7 : Calculate Bit Mask.....	46
3.2.3.6	Capability 3.8 : Calculate Extended Parameter.....	47
3.2.4	<i>Capability 4: Show Electrical/Engineering Data</i>	47
3.2.4.1	Capability 4.1 : Display Table	51
3.2.4.2	Capability 4.2 : Display Graphic	52



**SOFTWARE REQUIREMENTS
SPECIFICATION
for Airborne Real Time Instrumentation System**

Document No.
EM/000/SRS/DD/003

Revision: 1

3.2.4.3	Capability 4.3 : Display Mixed.....	52
3.2.4.4	Capability 4.4 : Display XPlot.....	52
3.2.4.5	Capability 4.5 : Print Parameter Data	53
3.2.5	<i>Capability 5 : Record Electrical/Engineering Data</i>	53
3.3	CSCI INTERNAL INTERFACES.....	55
3.4	CSCI DATA ELEMENT REQUIREMENTS.....	55
3.4.1	<i>External data</i>	55
3.4.2	<i>Internal data</i>	55
3.5	ADAPTATION REQUIREMENT	59
3.6	SIZING AND TIMING REQUIREMENTS	60
3.6.1	<i>Sizing requirements</i>	60
3.6.1.1	The Size of PCM Data.....	60
3.6.1.2	The Size of Hard Disk	61
3.6.2	<i>Timing of PCM Data</i>	61
3.7	SAFETY REQUIREMENTS	63
3.8	SECURITY REQUIREMENTS.....	63
3.9	DESIGN CONSTRAINTS	63
3.10	SOFTWARE QUALITY FACTORS.....	63
3.11	HUMAN PERFORMANCES/HUMAN ENGINEERING REQUIREMENTS.....	63
4	QUALIFICATION REQUIREMENTS	68
4.1	QUALIFICATION METHODS.....	68
4.2	SPECIAL QUALIFICATION REQUIREMENTS	71
5	PREPARATION FOR DELIVERY.....	72
6	NOTES	73



**SOFTWARE REQUIREMENTS
SPECIFICATION
for Airborne Real Time Instrumentation System**

**Document No.
EM/000/SRS/DD/003**

Revision: 1

**TABLE OF CONTENTS (Continued)
LIST OF FIGURES**

Figure 1 : "The ARTISt System Architecture".....	7
Figure 2 : "PCM Data Output from OBDAS to ARTISt ".....	8
Figure 3 : "PCM Data from ARTISt Card to The PC Memory".....	9
Figure 4 : "Data Context Diagram of ARTISt".....	12
Figure 5 : "DFD/CFD 0 ARTISt".....	14
Figure 6 : "State Transition Diagram of ARTISt".....	18
Figure 7 : "DFD/CFD 1 Initiate Program".....	20
Figure 8 : "State Transition Diagram of ARTISt in the Setting Mode".....	22
Figure 9 : "DFD/CFD 1.3 Setup Presentation".....	24
Figure 10 : "DFD/CFD 1.4 Generate PCMLUT".....	29
Figure 11 : "DFD/CFD 1.6 Report AC_Config".....	33
Figure 12 : "DFD/CFD 2 Collect Electrical Data from ACARD".....	37
Figure 13 : "DFD/CFD 3 Translate to Engineering Data".....	42
Figure 14 : "DFD/CFD 4 Show Electrical/Engineering Data".....	48
Figure 15 : "State Transition Diagram of ARTISt in the Running Mode".....	50
Figure 16 : "Size of PCM Data per Frame".....	60
Figure 17 : "Frame Acquisition Time".....	62



**SOFTWARE REQUIREMENTS
SPECIFICATION
for Airborne Real Time Instrumentation System**

**Document No.
EM/000/SRS/DD/003**

Revision: 1

**TABLE OF CONTENTS (Continued)
LIST OF TABLES**

Table 1 : "Data Context Diagram Interfaces"	13
Table 2 : "DFD/CFD 0 Interfaces"	17
Table 3 : "Process Activation Table of ARTIST"	18
Table 4 : "DFD/CFD 1 Interfaces"	22
Table 5 : "Process Activation Table of ARTIST"	22
Table 6 : "DFD/CFD 1.3 Interfaces"	25
Table 7 : "DFD/CFD 1.4 Interfaces"	30
Table 8 : "DFD/CFD 1.6 Interfaces"	34
Table 9 : "DFD /CFD 2 Interfaces"	38
Table 10 : "DFD/CFD 3 Interfaces"	44
Table 11 : "DFD/CFD 4 Interfaces"	49
Table 12 : "Process activation table of DFD/CFD 4"	51
Table 13 : "Data Requirement Of Internal Data"	59
Table 14 : "Table requirement traceability"	67
Table 15 : "Qualification Method"	70



**SOFTWARE REQUIREMENTS
SPECIFICATION
for Airborne Real Time Instrumentation System**

Document No.
EM/000/SRS/DD/003
Revision: 1

1 SCOPE

1.1 Identification

This Software Requirements Specifications (SRS) is applied to a system described as follow :

System identification number : ARTIS_t_System_001
System title : Airborne Real Time Instrumentation System
System abbreviation : ARTIS_t

This SRS is concern about the software package consisting of only one Computer Software Configuration Item (CSCI) as follow:

CSCI identification number : ARTIS_t_CSCI_001
CSCI title : Airborne Real Time Instrumentation System
CSCI abbreviation : ARTIS_t

1.2 CSCI Overview

Purpose of system :

ARTIS_t system is an instrumentation system based on Personal Computer (PC) which is installed on board the prototype aircraft to perform presentation of flight test data in real time. The presentation consists of display the data in table mode, display the data in graphic mode, display the data in mixed mode (table and graphic), and display the data in xplot mode (graphic between 2 parameters), and also print and record the data. The data which has been recorded by ARTIS_t, can be used by other software through the Disk Management System (DMS). The PC equipped with an interface for Pulse Code Modulation (PCM) decoder called ARTIS_t Card.

The following figure describes the system architecture of the ARTIS_t :

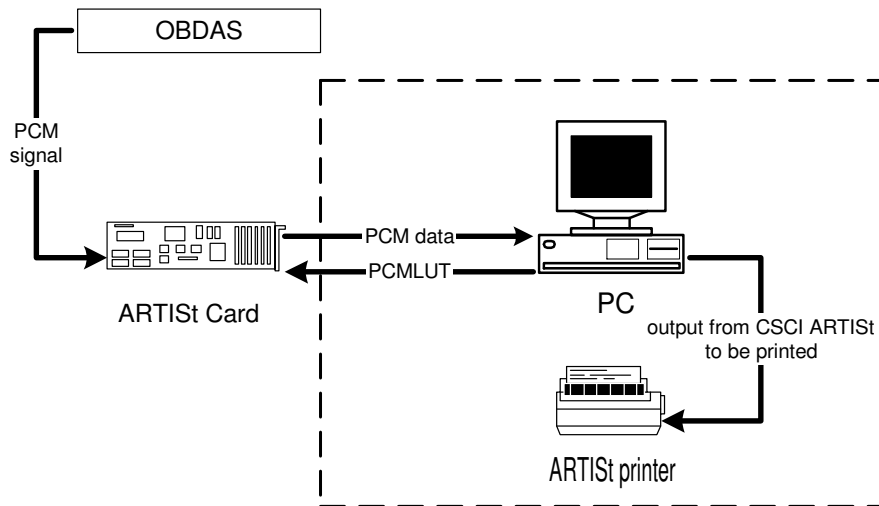

Figure 1 : "The ARTIS System Architecture"



**SOFTWARE REQUIREMENTS
SPECIFICATION
for Airborne Real Time Instrumentation System**

**Document No.
EM/000/SRS/DD/003**

Revision: 1

On Board Data Acquisition System (OBDAS) is an instrumentation system which is installed on the prototype aircraft directly acquires analog and digital signals from various flight test sensors and other measurement sub system and convert them into a format suitable for real time display, telemetry and recording.

ARTIS_t card is an instrumentation system which is installed inside the PC which must receive a serial PCM bit stream output incoming from OBDAS, decoding it, and then transferring the data to the PC memory based on Pulse Code Modulation Look Up Table (PCMLUT). One PCM data is 12 bits (1 word) long. There are parameters which have 1 word data and Aeronautical Radio Incorporated (ARINC) parameters which has 3 words data. PCMLUT is array of PCM word position, means parameter position inside PCM data stream, which is arranged according to calibration file. PCM frame size is equal the size of PCM bit stream decoded by OBDAS which has specific frame length and frame depth, and position of frame number.

The following figure describes PCM data generated out from OBDAS and received by ARTIS_t.

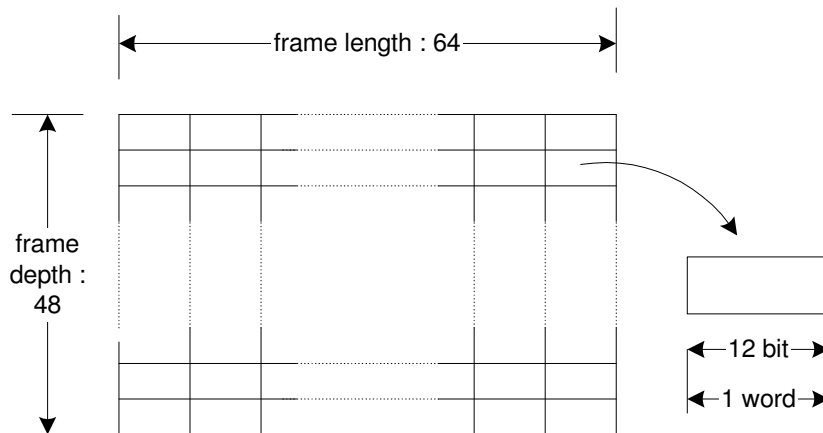

Note :
frame size : frame depth x frame length

Figure 2 : "PCM Data Output from OBDAS to ARTIS_t "

After passing through ARTIS_t card, the PCM data which goes out depending on PCMLUT. To regulate PCM data in PC memory, it is performed by the Non-Developmental Software (NDS) files. The NDS files are Art-buf and ISRPCM files.



**SOFTWARE REQUIREMENTS
SPECIFICATION
for Airborne Real Time Instrumentation System**

**Document No.
EM/000/SRS/DD/003**

Revision: 1

The following figure represents PCM data which goes to PC memory.

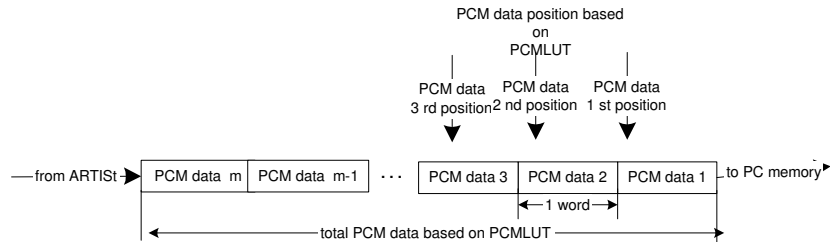

Note :

m : total pcm_data which goes out to PC memory based on PCMLUT.
(It can be said that **m** is sum pcm_data position)

Figure 3 : "PCM Data from ARTIST Card to The PC Memory"

Purpose of the CSCI :

ARTIST CSCI is a configuration item that is installed inside the PC and access the PCM data in the PC memory.

ARTIST CSCI should perform the following functions :

1. collect electrical data from ARTIST card
2. process the data : process to translate electrical data into engineering data and extended parameters calculation
3. present the data :
 - a. on-line displaying with status (displayed electrical data or engineering data in table mode or graphic mode or mixed mode or xplot mode),
 - b. on-line recording (electrical data and/or engineering data)
 - c. on-line printing (electrical data or engineering data)

ARTIST CSCI is able to process the all safety parameters used in prototype aircraft of IPTN. These parameters are defined by the Flight Test Engineer (FTE).

Electrical data is occurred because of a measurement device produce specific electrical voltage. PCM data is electrical data format. Then it is allocated in memory within hexadecimal value. Engineering data is readable data from engineering view. Actually, this engineering data will be got from calculation electrical data with specific formula based on calibration data (this data occurs from laboratory test).

Data collection is to select and to take electrical data which needed via ARTIST card. Data processing means that PCM data from ARTIST card will be translated from electrical data into engineering data and extended parameters calculation, based on calibration data which saved on calibration file with specific formula. Data presentation means, either electrical data or engineering data can be displayed on screen monitor (table mode and/or graphic mode), printed on printer and saved electrical data to the harddisk of PC.



**SOFTWARE REQUIREMENTS
SPECIFICATION**
for Airborne Real Time Instrumentation System

Document No.
EM/000/SRS/DD/003

Revision: 1

1.3 Document Overview

This document specifies the requirements to be satisfied by the ARTIS_t CSCI.
ARTIS_t CSCI has been connected directly within ARTIS_t Card (ACARD) on PC. ACARD shall receive data from On Board Data Acquisition System (OBDAS) in PCM frame format.
ARTIS_t can perform data collection, data processing and data presentation.
ARTIS_t is able to run on IBM PC/AT (or compatible) with minimum 486 processor and minimum ram 1 MB.
ARTIS_t is designed to have a delay time maximum up to 288 ms every data frame incoming for performing ARTIS_t capabilities.



**SOFTWARE REQUIREMENTS
SPECIFICATION**
for Airborne Real Time Instrumentation System

Document No.
EM/000/SRS/DD/003

Revision: 1

2 APPLICABLE DOCUMENTS

2.1 International documents

- [1] DOD-STD-2167A Military standard,
Defense System Software Development,
(issue date 29 February 1988).

2.2 THOMSON-CSF documents

- [2] RDL-101 Thomson-CSF standard,
Overview of Thomson-CSF Software Development Baseline
(issue date September 1993).
- [3] RDL-312 Thomson-CSF standard,
Drafting Guide for Software Requirements Specification (SRS),
(issue date September 1993).
- [4] GDL 10-3E Thomson-CSF standard,
Software Specification Procedure In The Thomson-CSF Baseline,
(issue date September 1993).

2.3 IPTN documents

- [5] EM/000/IRS/DD/002 Interface Requirements Specification for Airborne Real Time Instrumentation System,
(issue date November 2000).
- [6] PART 41 G – NCS 2001 IPTN Computational / Software Standard,
Airborne Software Standard,
(issue date July 08, 1998).
- [7] EM/000/PRO/AL/005 EM Division Procedures for Document and Data Control,
(Rev. 1, issue date November 1997).
- [8] EM/000/PRO/AL/026 EM Division Procedures for Software Design Control,
(Rev. 1, issue date November 1997)
- [9] EM/000/SDP/DD/001 Software Development Plan for Airborne Real Time Instrumentation System,
(issue date october 1999).
- [10] TN/N250/DAS/12/97/004 Functional Test On Board Data Acquisition System,
(issue date December 20, 1997)



3 ENGINEERING REQUIREMENTS

3.1 CSCI external interfaces requirements

Description :

This paragraph identifies the external interfaces of ARTIS CSCI and represents data and control of ARTIS in its environment. The Data Context Diagram or top level drawing is depicted below :

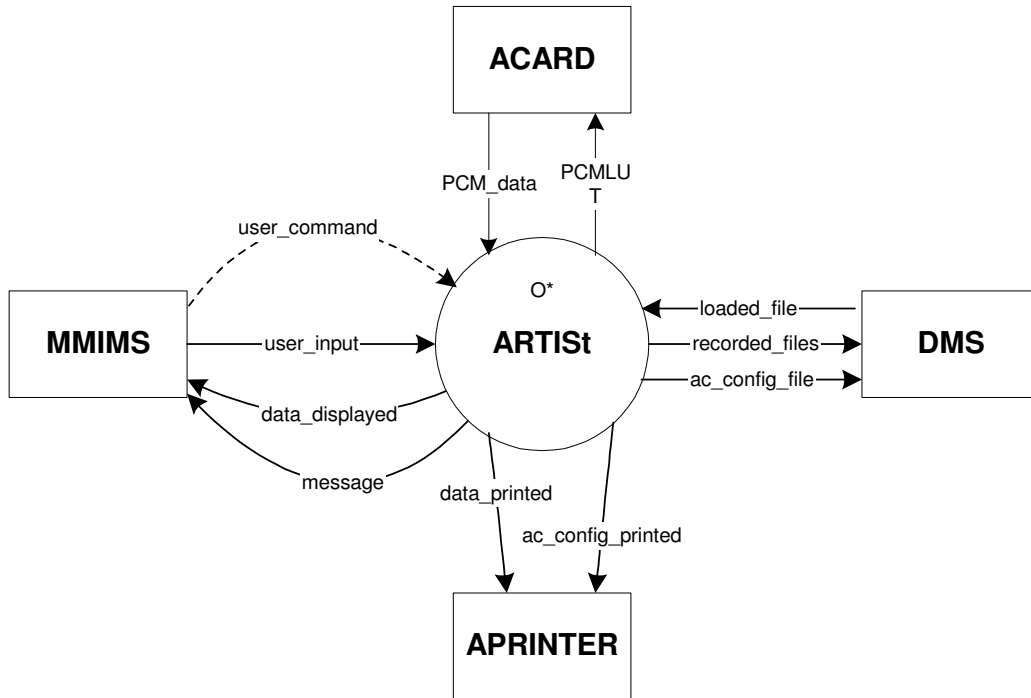

Figure 4 : "Data Context Diagram of ARTIS"

The following table summarizes the data and control interfaces of DCD.

<i>Name of data</i>	<i>Source</i>	<i>Destination</i>	<i>Description</i>	<i>Data/Control Flow Type</i>
user_command (IRS_REQ_21000)	MMIMS	ARTIS	signal sent to the CSCI.	input control
user_input (IRS_REQ_22000)	MMIMS	ARTIS	Arrange of calib_file_name, parameter-setup, graph-table-mode, selected-parameters, record_file_name, ac_config, ac_config_file_name, correct_formula	input data
data_displayed (IRS_REQ_23000)	ARTIS	MMIMS	Arrange of display_table, display_graphic, display_mixed, display_xplot	output data
message (IRS_REQ_24000)	ARTIS	MMIMS	This data flow carries message of system behavior	output data



**SOFTWARE REQUIREMENTS
SPECIFICATION
for Airborne Real Time Instrumentation System**

**Document No.
EM/000/SRS/DD/003**

Revision: 1

cont'd

<i>Name of data</i>	<i>Source</i>	<i>Destination</i>	<i>Description</i>	<i>Data/Control Flow Type</i>
data_printed (IRS_REQ_31000)	ARTISt	APRINTER	Arrange of set of parameter identification and electrical/engineering data parameter	output data
PCM_data (IRS_REQ_11000)	ACARD	ARTISt	12 bits data (1 word) transmitted from ACARD	input data
recorded_files (IRS_REQ_42000)	ARTISt	DMS	Arrange of name of recorded file, header of data recorded and electrical data to be recorded	output data
ac_config_file (IRS_REQ43000)	ARTISt	DMS	Arrange of name of A/C configuration file and A/C configuration data	output data
loaded_files (IRS_REQ_41000)	DMS	ARTISt	Arrange of configuration file, calibration file and formula file	Input data
PCMLUT (IRS_REQ_12000)	ARTISt	ACARD	Set of data indicated PCM position in sequence in order to be PCM_data	output data
ac_config_printed (IRS_REQ_32000)	ARTISt	APRINTER	aircraft configuration will be printed.	output data

Table 1 : "Data Context Diagram Interfaces"

3.2 CSCI capability requirements

This paragraph will describe all of capability requirements that ARTISt CSCI must satisfy.

The capabilities of the ARTISt CSCI are :

- Initiate Program
- Collect Electrical Data from ACARD
- Translate To Engineering Data
- Show Electrical/Engineering Data
- Record Electrical/Engineering Data

The DFD/CFD level 0 is drawn on the following page :



**SOFTWARE REQUIREMENTS
SPECIFICATION
for Airborne Real Time Instrumentation System**

Document No.
EM/000/SRS/DD/003

Revision: 1

ARTIS_t CSCI should be able to receive PCM data from ARTIS_t card in PCM stream format. The PCM data is processed into engineering data according to its calibration data. Either engineering or electrical data can be displayed in three mode graphics. The electrical data will be recorded including the calibration data. As long as ARTIS_t is displaying data (electrical or engineering) in real time, the data itself is able to be printed to APRINTER and to be recorded to DMS.

Param storage is a structure of the parameter attributes such as parameter's name, symbol, unit, etc. More detail of param can be seen in the paragraph 3.4.2.



**SOFTWARE REQUIREMENTS
SPECIFICATION
for Airborne Real Time Instrumentation System**

**Document No.
EM/000/SRS/DD/003**

Revision: 1

The following table summarizes the data interfaces of the DFD/CFD 0 (the more information can be found on the paragraph 3.4) :

<i>Name of data</i>	<i>Source</i>	<i>Destination</i>	<i>Description</i>	<i>Data/Control Flow Type</i>
setting_command	MMIMS	bar	command from user to set up system configuration	input control
setting_finish	MMIMS	bar	command from user to finish setting up of system configuration	input control
running_command	MMIMS	bar	command from user to activate the running state	input control
running_finish	MMIMS	bar	command from user to deactivate the running state	input control
user_command (IRS_REQ_21000)	MMIMS	Show Electrical/ Engineering Data Record Electrical Data	signal sent to the CSCI.	input control
User_input (IRS_REQ_22000)	MMIMS	Initiate Program Show Electrical/ Engineering Data Record Electrical Data	Arrange of calib_file_name, parameter-setup, graph-table-mode, selected-parameters, record_file_name, ac_config, ac_config_file_name, correct_formula	input data
data_displayed (IRS_REQ_23000)	Show Electrical/ Engineering Data	MMIMS	Arrange of display_table, display_graphic, display_mixed	output data
message (IRS_REQ_24000)	Initiate Program Save Electrical Data	MMIMS	This data flow carries message of system behavior	output data
data_printed (IRS_REQ_31000)	Save Electrical Data	APRINTER	Arrange of set of parameter identification and electrical/engineering data parameter	output data
PCM_data (IRS_REQ_11000)	ACARD	Collect Electrical Data from ACARD	12 bits data (1 word) transmitted from ACARD	input data
recorded_ files (IRS_REQ_42000)	Record Electrical Data	DMS	Arrange of name of recorded file, header of data recorded and electrical data to be recorded	output data
ac_config_file (IRS_REQ43000)	Initiate Program	DMS	Arrange of name of A/C configuration file and A/C configuration data	output data



**SOFTWARE REQUIREMENTS
SPECIFICATION
for Airborne Real Time Instrumentation System**

**Document No.
EM/000/SRS/DD/003**

Revision: 1

<i>Name of data</i>	<i>Source</i>	<i>Destination</i>	<i>Description</i>	<i>Data/Control Flow Type</i>
loaded_files (IRS_REQ_41000)	DMS	Initiate Program	Arrange of configuration file, calibration file and formula file	Input data
PCMLUT (IRS_REQ_12000)	Initiate Program	ACARD	Set of data indicated PCM position in sequence in order to be PCM_data	output data
Param	Initiate Program	Param(storage)	Set of behavior parameters	Internal data
	Param (data storage)	Initiate Program	Set of parameters structure needed to generate PCMLUT	Internal data
		Translate to Engineering Data	Calibration type of parameter and electrical parameters to be processed	Internal data
		Show Electrical/Engineering Data	Set of behavior parameters of engineering and electrical data	Internal data
		Record Electrical Data		
	Translate to Engineering Data	Param (data storage)	Set of engineering parameters and have been calculated	Internal data
	Collect Electrical Data from ACARD	Param (data storage)	set of electrical data inside elements of param structure	
selected_formula	Initiate Program	Translate to Engineering Data	Formula used for Extended parameter	Internal data
calib_data	Initiate Program	Save Electrical Data	Data calibration for parameter	internal data
		Translate to Engineering Data		
Irigtime	Initiate Program	Show Electrical/Engineering Data	IRIGtime result	Internal data
setup_result	Initiate Program	Show Electrical/Engineering Data	Mode of display, with reduction or without and number(name) or symbol	Internal data
loc_selected	Initiate Program	Show Electrical/Engineering Data	Entry parameter for displaying and printing	Internal data
loc_par	Initiate Program	Translate to Engineering Data	parameter has been defined for being calculation to translate into engineering data	Internal data
num_of_parameter	Initiate Program	Collect Electrical Data from ACARD	Total parameter attached	internal data

Table 2 : “DFD/CFD 0 Interfaces”



**SOFTWARE REQUIREMENTS
SPECIFICATION**
for Airborne Real Time Instrumentation System

Document No.
EM/000/SRS/DD/003

Revision: 1

3.2.1 Capability 1: Initiate Program

Description :

Purpose of this process is to Initiate or making set up to the program based on inputs from user in the beginning. There is a file that must be loaded first. The file (config_file (IRS_REQ_41100)) must be available in storage.

This capability is broken down into 6 capabilities as follows :

- Initiate System Configuration
- Define Parameters
- Setup Presentation
- Generate PCMLUT
- Select Extended Formula
- Report AC_Config

The DFD/CFD 1 " Initiate program" is depicted on the following page :



**SOFTWARE REQUIREMENTS
SPECIFICATION
for Airborne Real Time Instrumentation System**

**Document No.
EM/000/SRS/DD/003**

Revision: 1

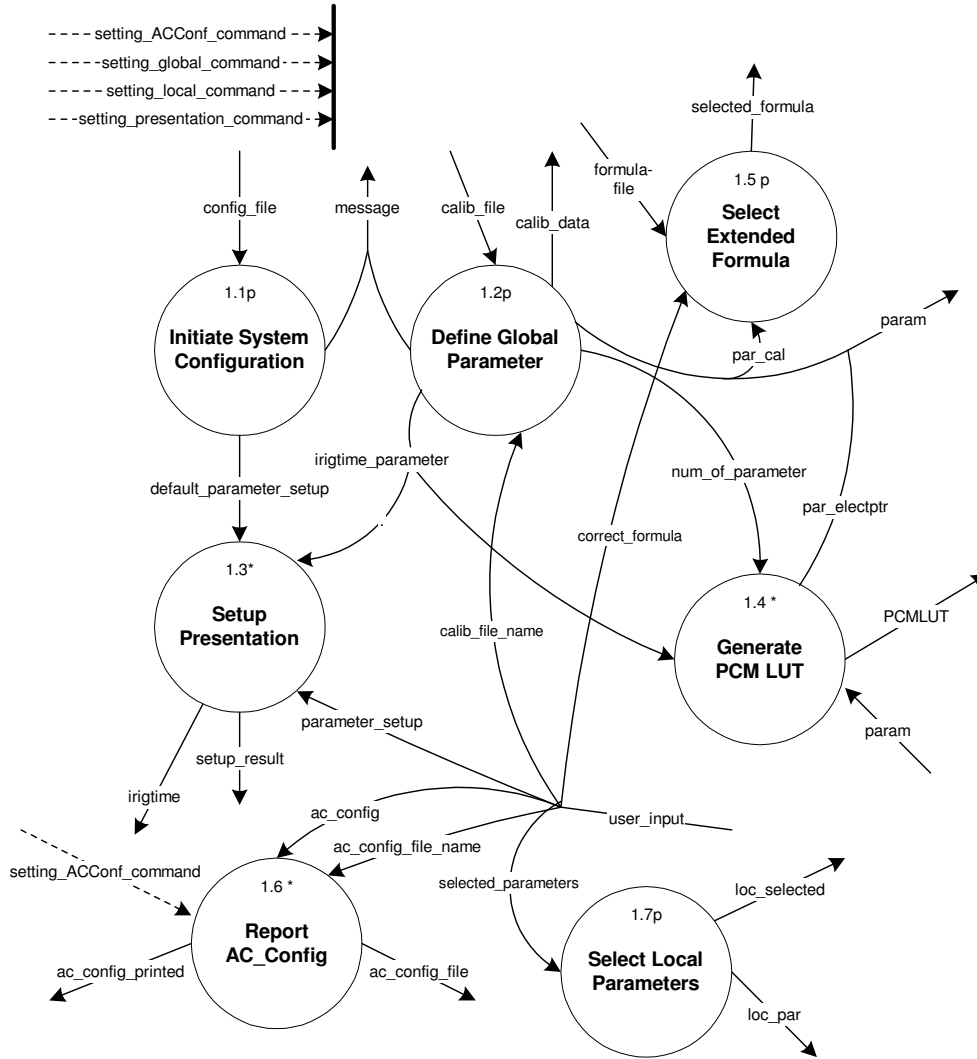

Figure 7 : "DFD/CFD 1 Initiate Program"



**SOFTWARE REQUIREMENTS
SPECIFICATION
for Airborne Real Time Instrumentation System**

**Document No.
EM/000/SRS/DD/003**

Revision: 1

The following table summarizes the data interfaces of the DFD/CFD 1.

<i>Name of Data</i>	<i>Source</i>	<i>Destination</i>	<i>Description</i>	<i>Data /Control Flow Type</i>
setup_result	Setup Presentation	Show Electrical/Engineering Data	Mode of display, with reduction or without and number(name) or symbol	Output data
parameter_setup (IRS_REQ_22200)	MMIMS	Setup Presentation	parameter to setup presentation	Input Data
calib_file_name (IRS_REQ_22100)	MMIMS	Define Parameter	name of calibration file	input data
param	Define Parameter	Param (data storage)	Parameters identification to be processed	output data
	Param (data storage)	Generate PCM LUT	Parameters identification needed to Generate PCMLUT	input data
	Generate PCM LUT	Param (data storage)	Vector to electrical data	output data
Selected_parameters (IRS_REQ_22400)	MMIMS	Define Parameter	This data flow carries selection of parameters to be displayed or printed	Input data
loc_par	Define Parameter	Translate to Engineering Data	parameter has been defined for being calculation to translate into engineering data	output data
calib_data	Define Parameter	Translate to Engineering Data	set of calibration data to be processed	output data
		Show Electrical/Engineering Data	set of calibration data to be recorded	
loc_selected	Define Parameter	Show Electrical/Engineering Data	Entry parameter for displaying and printing	output data
num_of_parameter	Define Parameter	Generate PCMLUT	total parameters inside calibration file	internal data
message (IRS_REQ_24000)	Initiate System Configuration	MMIMS	This data flow carries message of system behavior	output data
	Define Parameter			
selected_formula	Select Extended Formula	Translate to Engineering Data	Formula has been defined, sends to the Extended parameter	output data
irigtime	Setup Presentation	Show Electrical/Engineering Data	IRIGtime result	output data
config_file (IRS_REQ_41100)	DMS	Initiate System Configuration	File contains configuration setting for initialization program	input data
calib_file (IRS_REQ_41200)	DMS	Define Parameter	File contains calibration of parameter identification, pcm position, and calibration data.	input data
Formula_file (IRS_REQ_41300)	DMS	Select Extended Formula	File contains formulas used for derivative parameter	input data



**SOFTWARE REQUIREMENTS
SPECIFICATION
for Airborne Real Time Instrumentation System**

Document No.
EM/000/SRS/DD/003
Revision: 1

cont'd

<i>Name of Data</i>	<i>Source</i>	<i>Destination</i>	<i>Description</i>	<i>Data /Control Flow Type</i>
Correct_formula	MMIMS	Select Extended Formula	Arithmetic operation formula for determining derivative parameter	Input data
irigtime_parameter	Define Parameter	Setup Presentation Generate PCM LUT	parameter for IRIGtime	internal data
De-default_parameter_setup	Initiate System Configuration	Setup Presentation	parameter data loaded from a file for making setup presentation	internal data
par_cal	Define Parameters	Define Extended Parameter	Type of parameter calibration used for determining Extended parameter	Internal data

Table 4 : "DFD/CFD 1 Interfaces"

The following State Transition Diagram (STD) describe the behavior of ARTIST CSCI in the setting mode:

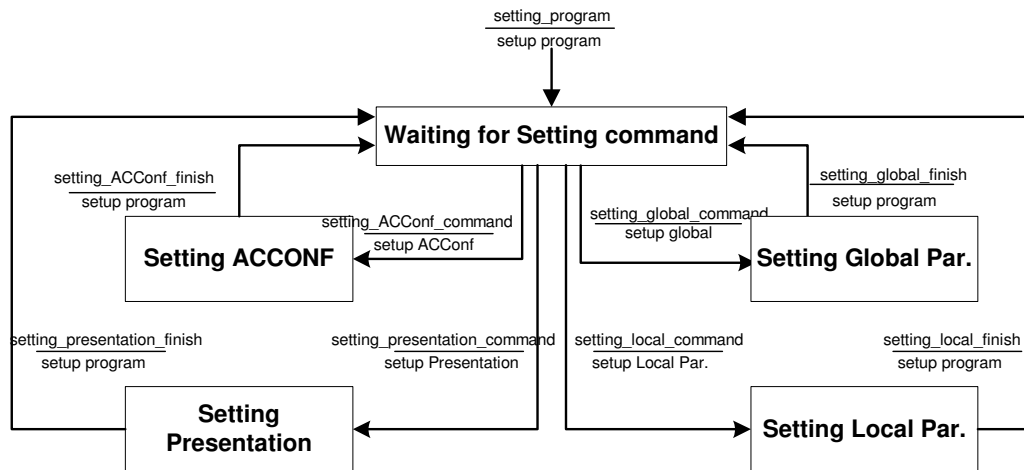

Figure 8 : "State Transition Diagram of ARTIST in the Setting Mode"

The following Process Activation Table (PAT) represents the behavior of ARTIST CSCI in the setting mode:

Action	Initiate System Config (1.1p)	Define Global Parameter (1.2p)	Setup Presentation (1.3*)	Generate PCMLUT (1.4*)	Select Extended Formula (1.5p)	Report ACConfig (1.6*)	Select Local Parameters (1.7p)
Setup ACConf	0	0	0	0	0	1	0
Setting global	0	1	0	0	0	0	0
Setting local Par.	0	0	0	0	0	0	1
Setup presentation	0	0	1	0	0	0	0

note : 1 : active 0 : not active

Table 5 : "Process Activation Table of ARTIST"



**SOFTWARE REQUIREMENTS
SPECIFICATION
for Airborne Real Time Instrumentation System**

**Document No.
EM/000/SRS/DD/003**

Revision: 1

3.2.1.1 Capability 1.1 : Initiate System Configuration

Description :

This capability allows to load configuration file from storage. Information inside this file should be passed out as default parameter. This will set up early presentation. .

Process Specification (PSPEC) of capability 1.1 : Initiate System Configuration

1. This process has 3 data/control flows :

Input data : config_file

Output data : message, default_parameter_setup

2. Description :

(SRS_REQ_11000)

BEGIN

This capability shall load config_file (slave.ini), in the DMS. If this file does not exist, error message shall be occurred in MMIMS. If so, capability shall read the file to determine default_parameter_setup, and then send those to setup presentation in order to initiate the program.

END

3.2.1.2 Capability 1.2 Define Global Parameter

The objective of this capability is to define global parameters to be put into param structure.

Process Specification (PSPEC) of capability 1.2.1 : Define Global Parameter

1. This capability has 7 data flows :

Input data : calib_file, calib_file_name

Output data : calib_data, param, num_of_parameter , irigtime_parameter, message

2. Description :

(SRS_REQ_12100)

BEGIN

This capability shall load the calib_file according to the calib_file_name. Based on the calib_file, CSCI shall construct the param and calib_data and then count the total parameter.

END

3.2.1.3 Capability 1.3 Setup Presentation (SRS_REQ_13000)

The objective is to define mode of presentation based on input from user. This capability is broken down into 4 capabilities as follows:

- setup IRIGtime
- setup DisMod
- setup FramRed
- setup NumSym



SOFTWARE REQUIREMENTS SPECIFICATION
for Airborne Real Time Instrumentation System

Document No.
EM/000/SRS/DD/003

Revision: 1

The DFD/CFD Setup Presentation is depicted on the below :

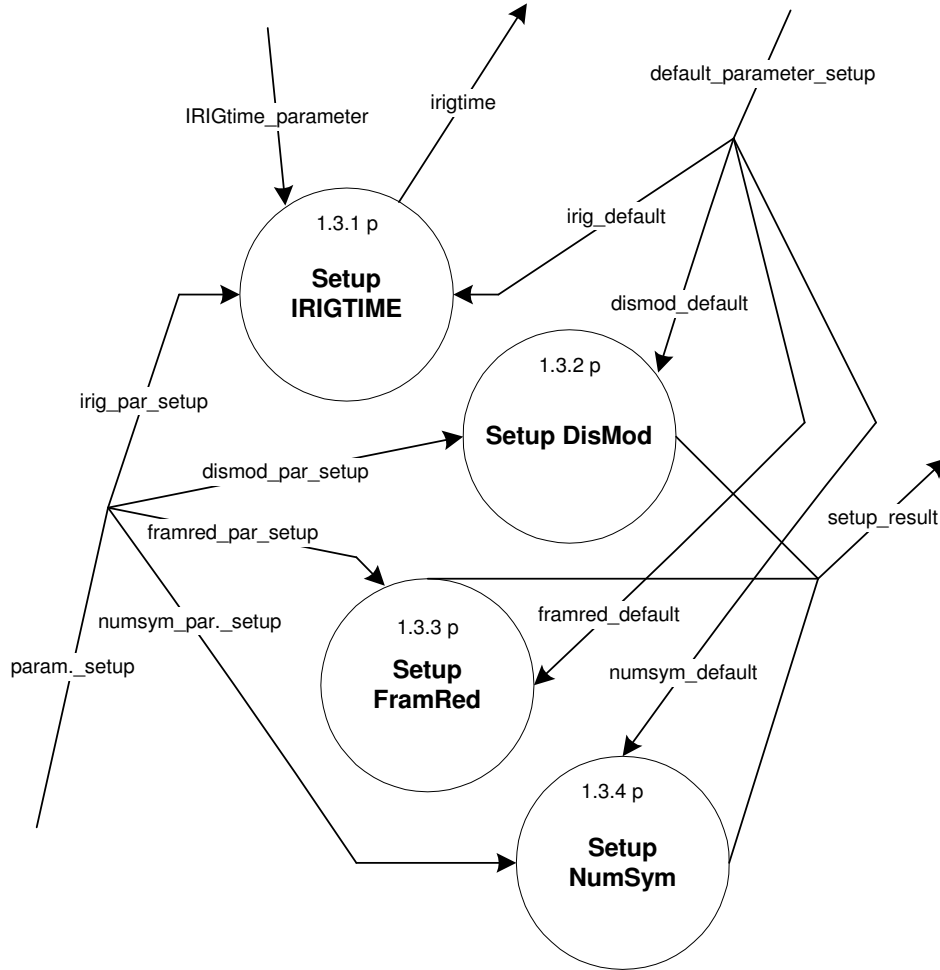

Figure 9 : "DFD/CFD 1.3 Setup Presentation"



**SOFTWARE REQUIREMENTS
SPECIFICATION
for Airborne Real Time Instrumentation System**

**Document No.
EM/000/SRS/DD/003**

Revision: 1

The following table represents of DFD/CFD 1.3 Setup Presentation :

<i>Name of Data</i>	<i>Source</i>	<i>Destination</i>	<i>Description</i>	<i>Data /Control Flow Type</i>
irig_par_setup (IRS_REQ_22230)	MMIMS	Setup Irigtime	The user selects irigtime mode. Defined as : 1=Teledyne separated; 2=Teledyne compact; 3=Aydin Vector separated; 4=Aydin Vector compact; 5=Generated by computer	input data
Dismod_par_setup (IRS_REQ_22210)	MMIMS	Setup DisMod	The user selects display mode. Defined as : 1=elect; 2=eng	input data
Framred_par_setup (IRS_REQ_22220)	MMIMS	Setup FramRed	The user selects framred mode. Defined as : 1=with framred; 2=without framred	input data
Num-sym_par_setup (IRS_REQ_22240)	MMIMS	Setup NumSym	The user selects numsym mode. Defined as : 1=par_name;2=par_sym	input data
irigtime_parameter	Define Global Parameter	Setup Irigtime	irigtime parameter position	input data
irigtime	Setup Irigtime	Show Electrical/Engineering Data	Represent of IRIG TIME used.	output data
irig_default	Initiate System Configuration	Setup Irigtime	default of irigtime used. Defined as : 1=Teledyne separated; 2=Teledyne compact; 3=Aydin vector separated; 4=Aydin vector compact; 5=Generated by computer;	input data
dismod_default	Initiate System Configuration	Setup DisMod	default of display mode. Defined as : 1=elect; 2=eng;	input data
framred_default	Initiate System Configuration	Setup FramRed	default of framred mode. Defined as : 1=with framred; 2=without framred	input data
numsym_default	Initiate System Configuration	Setup NumSym	default of numsym mode. Defined as : 1=par_name; 2=par_sym	input data
setup_result	Setup DisMod	Show Electrical/Engineering Data	Mode of display, with reduction or without and number(name) or symbol	output data
	Setup FramRed			
	Setup NumSym			

Table 6 : "DFD/CFD 1.3 Interfaces"



**SOFTWARE REQUIREMENTS
SPECIFICATION
for Airborne Real Time Instrumentation System**

Document No.
EM/000/SRS/DD/003

Revision: 1

3.2.1.3.1 Capability 1.3.1 Setup IRIGtime

The objective is to define irigtime after irig_par_setup defined based on irigtime_parameter.
This capability has 4 data flows .

Process Specification (PSPEC) of capability 1.3.1 : Setup IRIGtime

1. This capability has 4 data flows :

Input data : irig_par_setup, irigtime_parameter, irig_default

output data : irigtime

2. Description :

(SRS_REQ_13100)

BEGIN

The capability must determine irigtime from calculation based on irigtime_parameter. CSCI has to find out whether irig_par_setup was defined from MMIMS. If yes, irig_default loaded from config_file will be disable. If not, CSCI will use irig_default from configuration file.

END

3.2.1.3.2 Capability 1.3.2 Setup DisMod

The objective is to determine mode of display.

Process Specification (PSPEC) of capability 1.3.2 : Setup DisMod

1. This capability has 3 data flows :

Input : dismod_par_setup, dismod_default

Output : setup_result

2. Description :

(SRS_REQ_13200)

BEGIN

This capability may receive dismod_par_setup from MMIMS. If no dismod_par_setup come in, CSCI will use dismod default given by configuration file.

END



**SOFTWARE REQUIREMENTS
SPECIFICATION**
for Airborne Real Time Instrumentation System

Document No.
EM/000/SRS/DD/003

Revision: 1

3.2.1.3.3 Capability 1.3.3 Setup FramRed

The objective is to determine behavior of frame.

Process Specification (PSPEC) of capability 1.3.3 : Setup FramRed

1. This capability has 3 data flows.

Input : framred_par_setup, framred_default

Output : setup_result

2. Description :

(SRS_REQ_13300)

BEGIN

This capability may receive framred_par_setup from MMIMS. If there is no input from user, it will be defined by framred_default.

END

3.2.1.3.4 Capability 1.3.4 Setup NumSym

The objective is to determine number(name) or symbol needed.

Process Specification (PSPEC) of capability 1.3.4 : Setup NumSym

1. This capability has 3 data flows .

Input : numsym_par_setup, numsym_default

Output : setup_result

2. Description :

(SRS_REQ_13400)

BEGIN

This capability must define number or symbol required according to numsym_par_setup. If numsym_par_setup does not come, CSCI will determine number or symbol based on numsym_default.

END



**SOFTWARE REQUIREMENTS
SPECIFICATION**
for Airborne Real Time Instrumentation System

Document No.
EM/000/SRS/DD/003

Revision: 1

3.2.1.4 Capability 1.4 Generate PCMLUT (SRS_REQ_14000)

The objective is to generate PCM Look Up Table and vector to electrical data to be processed.

This capability has 5 data flows.

Input : num_of_parameter , irigtime_parameter, param

output : elect_ptr, PCMLUT

This capability is broken down into 6 capabilities as follows:

- Create Parameter Vector
- Append System Vector
- Append Vector of Multiword Parameter
- Sort Vector
- Compress Vector
- Update Parameter Vector

The DFD/CFD Generate PCMLUT is drawn on the following page :



SOFTWARE REQUIREMENTS SPECIFICATION
for Airborne Real Time Instrumentation System

Document No.
EM/000/SRS/DD/003
Revision: 1

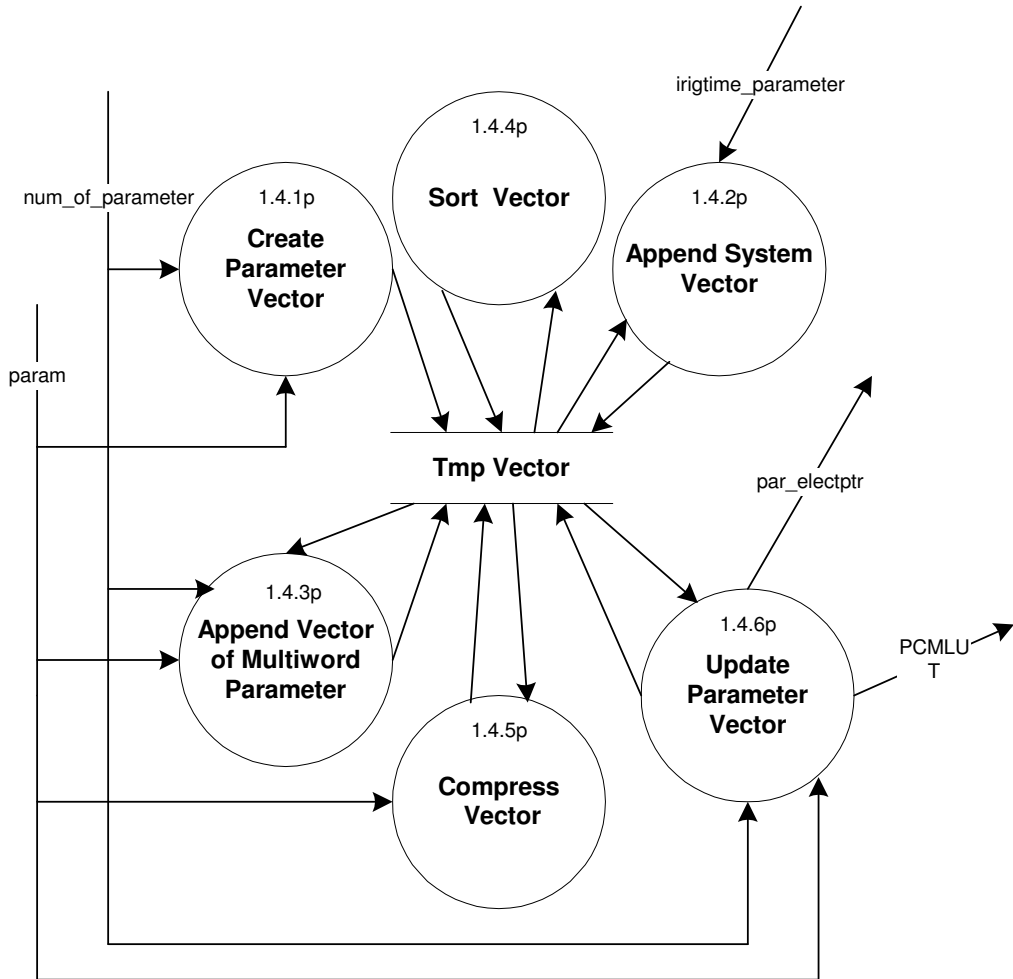

Figure 10 : "DFD/CFD 1.4 Generate PCMLUT"



**SOFTWARE REQUIREMENTS
SPECIFICATION
for Airborne Real Time Instrumentation System**

**Document No.
EM/000/SRS/DD/003**

Revision: 1

The following table represents of DFD/CFD 1.4 interfaces:

<i>Name of Data</i>	<i>Source</i>	<i>Destination</i>	<i>Description</i>	<i>Data /Control Flow Type</i>
param	param (data storage)	Create Parameter Vector	Set of parameters structure needed to generate PCMLUT	input data
		Append Vector of Multiword Parameter		
		Compress Vector		
		Update Parameter Vector		
num_of_parameter	Define Global Parameter	Create Parameter Vector	total parameters inside calibration file	input data
		Append Vector of Multiword Parameter		
		Update Parameter Vector		
irigtime_parameter	Define Global Parameter	Append System Vector	irigtime parameter position	input data
par_electptr	Update Parameter Vector	Param (data storage)	Vector to electrical data buffer.	output data
PCMLUT (IRS_REQ_12000)	Update Parameter Vector	ACARD	Set of data indicated PCM position in sequence in order to be PCM_data	output data
Tmp_vector	Create Parameter Vector	Tmp_vector (data storage)	temporarily buffer contains array of vector to PCM data	internal data
	Sort Vector			
	Append System Vector			
	Append Vector of Multiword Parameter			
	Compress Vector			
	Update Parameter Vector			
	Tmp_vector (data storage)	Sort Vector		
		Append System Vector		
		Append Vector of Multiword Parameter		
		Compress Vector		
		Update Parameter Vector		
		Update Parameter Vector		

Table 7 : "DFD/CFD 1.4 Interfaces"



**SOFTWARE REQUIREMENTS
SPECIFICATION
for Airborne Real Time Instrumentation System**

**Document No.
EM/000/SRS/DD/003**

Revision: 1

3.2.1.4.1 Capability 1.4.1 Create Parameter Vector

Process Specification (PSPEC) of capability 1.4.1 : Create Parameter Vector

1. This capability has 3 data flows.

Input : num_of_parameter , param

Output : Tmp_vector

2. Description :

(SRS_REQ_14100)

BEGIN

This capability is to create array vector of parameter with total element depend on num_of_parameter.

END

3.2.1.4.2 Capability 1.4.2 Append System Vector

Process Specification (PSPEC) of capability 1.4.2 : Append System Vector

1. This capability has 3 data flows.

Input : irigtime_parameter, Tmp_vector

Output : Tmp_vector

2. Description :

(SRS_REQ_14200)

BEGIN

This capability is to append the vector of system (irigtime_parameter) into array vector of parameter.

END

3.2.1.4.3 Capability 1.4.3 Append Vector of Multiword Parameter

Process Specification (PSPEC) of capability 1.4.3 : Append Vector of Multiword Parameter

1. This capability has 4 data flows.

Input : num_of_parameter , param, Tmp_vector

Output : Tmp_vector

2. Description :

(SRS_REQ_14300)

BEGIN

- Determine the availability of parameters whose more than one PCM word
- Append vector of multiword into array vector of parameter

END



**SOFTWARE REQUIREMENTS
SPECIFICATION**
for Airborne Real Time Instrumentation System

Document No.
EM/000/SRS/DD/003

Revision: 1

3.2.1.4.4 Capability 1.4.4 Sort Vector

Process Specification (PSPEC) of capability 1.4.4 : Sort Vector

1. This capability has 2 data flows.

Input : Tmp_vector

Output : Tmp_vector

2. Description :

(SRS_REQ_14400)

BEGIN

This capability is to sort array vector of parameter.

END

3.2.1.4.5 Capability 1.4.5 Compress Vector

Process Specification (PSPEC) of capability 1.4.5 : Compress Vector

1. This capability has 3 data flows.

Input : Tmp_vector, param

Output : Tmp_vector

2. Description :

(SRS_REQ_14500)

BEGIN

This capability is to compress array vector of parameter.

END

3.2.1.4.6 Capability 1.4.6 Update Parameter Vector

Process Specification (PSPEC) of capability 1.4.6 : Update Parameter Vector

1. This capability has 5 data flows.

Input : param, num_of_parameter , Tmp_vector

Output : Tmp_vector, elect_ptr

2. Description :

(SRS_REQ_14600)

BEGIN

This capability is to define vector to array of parameter vector.

END



**SOFTWARE REQUIREMENTS
SPECIFICATION
for Airborne Real Time Instrumentation System**

Document No.
EM/000/SRS/DD/003
Revision: 1

3.2.1.5 Capability 1.5 Select Extended Formula

The objective is to define formula used for extended parameter based on formula_file.

Process Specification (PSPEC) of capability 1.5 : Select Extended Formula

1. This capability has 4 data/control flows.

Input : par_cal, formula_file, correct_formula

Output : selected_formula

2. Description :

(SRS_REQ_15100)

BEGIN

The capability shall load the formula_file from DMS.

If the correct_formula is found then issues selected_formula.

If not found then user must fill the new formula for Extended parameter onto the file

END

3.2.1.6 Capability 1.6 Report AC_Config

The objective of this capability is to report the aircraft configuration (ac_config) of flight test. The report include record the ac_config to the disk and print the ac_config to the printer. This capability is broken down into 2 capabilities as follows:

- Print AC_Config
- Record AC_Config

Following is the DFD/CFD 1.6 "Report AC_Config":

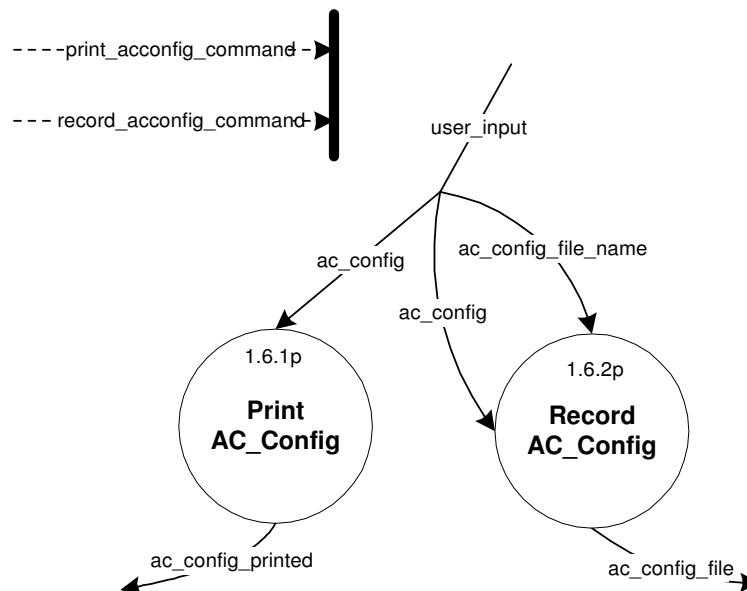

Figure 11 : "DFD/CFD 1.6 Report AC_Config"



**SOFTWARE REQUIREMENTS
SPECIFICATION
for Airborne Real Time Instrumentation System**

**Document No.
EM/000/SRS/DD/003**

Revision: 1

The following table summarizes the data interfaces of the DFD/CFD 1.6.

<i>Name of Data</i>	<i>Source</i>	<i>Destination</i>	<i>Description</i>	<i>Data /Control Flow Type</i>
ac_config_file (IRS_REQ43000)	Record AC_Config	DMS	Arrange of name of A/C configuration file and A/C configuration data	output data
ac_config_file_name (IRS_REQ_22500)	MMIMS	Record AC_Config	name of ac_config file.	Input data
re- cord_aconfig_comman d	MMIMS	Record AC_Config	command from user for record the ac_config	input control
print_aconfig_comman d	MMIMS	Print AC_Config	command from user for print the ac_config	input control
ac_config_printed (IRS_REQ_32000)	Print AC_config	APRINTER	aircraft configuration to be printed.	Output data
ac_config (IRS_REQ_22600)	MMIMS	Record AC_config	configuration of aircraft.	Input data

Table 8 : "DFD/CFD 1.6 Interfaces"

3.2.1.6.1 Capability 1.6.1 Print AC_Config

The objective of this capability is to print the aircraft configuration (ac_config) to the printer.

Process Specification (PSPEC) of capability 1.6.1 : Print AC_Config

1. This capability has 2 data flows (or controls)

- Input data : AC_config_data;
- Output data : AC_config_printed;

2. Description :

(SRS_REQ_16100)

BEGIN

This capability shall print aircraft configuration according to the entry from user.

END



**SOFTWARE REQUIREMENTS
SPECIFICATION
for Airborne Real Time Instrumentation System**

**Document No.
EM/000/SRS/DD/003**

Revision: 1

3.2.1.6.2 Capability 1.6.2 Record AC_Config

The objective of this capability is to record the aircraft configuration (ac_config) to the disk.

Process Specification (PSPEC) of capability 1.6.2 : Record AC_Config

1. This capability has 3 data flows (or controls)

- Input data : ac_config, ac_config_file_name;
- Output data : ac_config_file;

2. Description :

(SRS_REQ_16200)

BEGIN

This capability shall record aircraft configuration according to the user input (data and file name) in text file format.

END

3.2.1.7 Capability 1.7 Select Local Parameters

The objective is to select Local Parameter to be set up to CSCI according to user input.

Process Specification (PSPEC) of capability 1.7 : Select Local Parameter

1. This capability has 3 data (control) flows :

- Input data : selected_parameter
- Output data : loc_par, loc_selected

2. Description :

(SRS_REQ_12200)

BEGIN

The capability has to choose parameters available on param, according input from user (selected_parameters). To choose parameters, it depends on the user needed. Parameters for displaying table (tab_loc_selected), graphic (graph_loc_selected), mixed (mixed_loc_selected), or for printing (print_loc_selected) may be different or similar. The capability must issue loc_par and loc_selected.

END



**SOFTWARE REQUIREMENTS
SPECIFICATION**
for Airborne Real Time Instrumentation System

Document No.
EM/000/SRS/DD/003

Revision: 1

3.2.2 Capability 2 : Collect Electrical Data from ACARD

Description :

(SRS_REQ_20000)

BEGIN

The purpose of this capability is to collect data from ARTISt Card passing through non-developmental software ISRPCM.com and ArtBuf.com.

END

The data from ACARD is in PCM stream format. The CSCI ARTISt will take data indicated with vector.



SOFTWARE REQUIREMENTS SPECIFICATION
for Airborne Real Time Instrumentation System

Document No.
EM/000/SRS/DD/003

Revision: 1

This capability is broken down into 5 capabilities as follows :

- find buffer location
- find ISRPCM
- Store Address Buffer to ISRPCM
- Put Electrical Data to Param

ISRPCM.com and ArtBuf.com are included here as non-developmental software.

The Data Flow Diagram (DFD) / Control Flow Diagram (CFD) 2 is depicted on the following page :

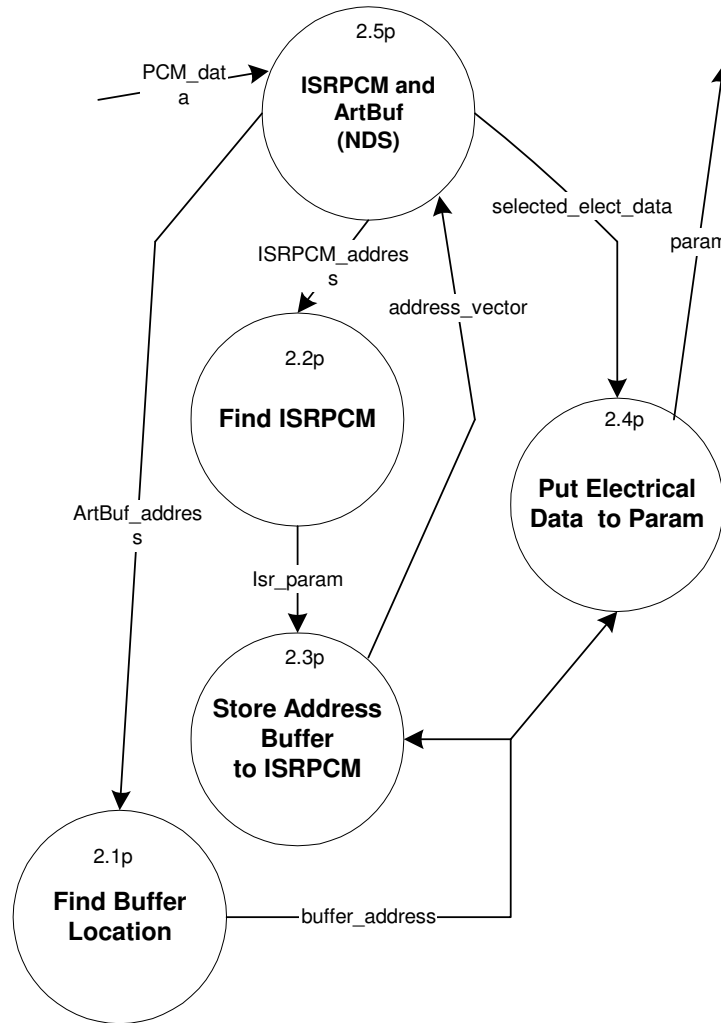

Figure 12 : "DFD/CFD 2 Collect Electrical Data from ACARD"



**SOFTWARE REQUIREMENTS
SPECIFICATION
for Airborne Real Time Instrumentation System**

Document No.
EM/000/SRS/DD/003

Revision: 1

The following table summarizes the data interfaces of the DFD/CFD 2.

<i>Name of data</i>	<i>Source</i>	<i>Destination</i>	<i>Description</i>	<i>Data/Control Flow Type</i>
Param	Put Electrical Data to Param	Param (data storage)	element of structure contains electrical data	output data
PCM_data (IRS_REQ_11000)	ACARD	ISRPCM and ArtBuf (NDS)	12 bits data (1 word) transmitted from ACARD	input data
ArtBuf_address	ISRPCM and ArtBuf (NDS)	Find Buffer Location	location of ArtBuf.com while it is resident in RAM	internal data
buffer_addresses	Find Buffer Location	Store Address Buffer to ISRPCM Put Electrical Data to Param	Address of : - PCM buffer 1 in memory - PCM buffer 2 in memory - Read buffer in memory	internal data
ISRPCM_address	ISRPCM and ArtBuf (NDS)	Find ISRPCM	location of ISRPCM.com while it is resident in memory RAM	internal data
isr_param	Find ISRPCM	Store Address Buffer to ISRPCM	converted address arranges of segment and offset of ISRPCM.com	internal data
address_vector	Store Address Buffer to ISRPCM	ISRPCM and ArtBuf (NDS)	vector which contains of address PCM buffer1 and address PCM buffer 2	internal data
read_buffer_vector	Point to Read Buffer	ISRPCM and ArtBuf (NDS)	Vector which contains first address of read buffer in memory	internal data
selected_elect_data	ISRPCM and ArtBuf (NDS)	Put Electrical Data to Param	electrical data pass out from memory according to PCMLUT	internal data

Table 9 : “DFD /CFD 2 Interfaces”

3.2.2.1 Capability 2.1 : Find Buffer Location

The objective is to find the location of ArtBuf.com file (*see SDP paragraph 4.3*) while resident in ram (random access memory) PC.

ArtBuf.com file has responsible for creating three buffers then always keep staying in RAM (resident). Those three buffers are named as PCM buffer 1, PCM buffer 2 and read buffer .

At the first time, PCM_data sent from ACARD will fill PCM buffer 1. When EOC (end of cycle) is incoming, it will sign to switch direction of the next PCM_data incoming from ACARD to the PCM buffer 2. While PCM_data is filling PCM buffer 2, the ingredients of PCM buffer 1 is removed to Read buffer. Then insides of Read buffer will be read in order to get the electrical data.

Process Specification (PSPEC) of capability 2.2 : Find Buffer Location

1. This process has 2 data/control flows :

Input data/control : ArtBuf_address

Output data/control: buffer_addresses



**SOFTWARE REQUIREMENTS
SPECIFICATION
for Airborne Real Time Instrumentation System**

**Document No.
EM/000/SRS/DD/003**

Revision: 1

2. Description :

(SRS_REQ_21000)

BEGIN

CSCI ARTISt will search the absolute address of ArtBuf.com

Then, address of PCM buffer 1, address of PCM buffer 2 and address of Read buffer in PC are found.

Address of PCM buffer 2 is ((the end address of PCM buffer 1) + 1000).

Address of Read buffer is ((the end address of PCM buffer 1) + 2000).

END

3.2.2.2 Capability 2.2 : Find ISRPCM

The objective is to find ISRPCM.com in memory resident.

ISRPCM.com has responsible for switching PCM_data direction, from PCM buffer 1 into PCM buffer 2. ISRPCM shall activate the interrupt from ACARD to CPU (hardware interrupt).

Process Specification (PSPEC) of capability 2.3 : Find ISRPCM

1. This process has 2 data flows (or controls) :

Input data/control : ISRPCM_address

Output data/control: ISR_param

2. Description :

(SRS_REQ_22000)

BEGIN

This capability will search the absolute address of ISRPCM.com

ISR_param will be the far vector of Segment and Offset address of ISRPCM file

END

3.2.2.3 Capability 2.3 : Store Address Buffer to ISRPCM

The objective is to store vector of buffers in ARtBuf.com file.

Segment and offset address of PCM buffer 1 and PCM buffer 2, will be allocated in ISR_param.

Process Specification (PSPEC) of capability 2.4 : Store Address Buffer to ISRPCM

1. This process has 3 data/control flows :

Input data/control : isr_param, buffer_addresses

Output data/control: adres_vector

2. Description :

(SRS_REQ_23000)

BEGIN

The capability shall receive address of PCM buffer 1 and PCM buffer 2.

Then, adres_vector is the far arrow of both buffers.

and will take a place in isr_param. Then, first address of PCM buffer 1 and first address of PCM buffer 2 store to ISRPCM.com

END



**SOFTWARE REQUIREMENTS
SPECIFICATION
for Airborne Real Time Instrumentation System**

**Document No.
EM/000/SRS/DD/003**

Revision: 1

3.2.2.4 Capability 2.4 : Put Electrical Data to Param

The objective is to obtain the electrical data from Read buffer in ArtBuf.com file, to the structure of param, when end of cycle from ACARD has been received.

Process Specification (PSPEC) of capability 2.6 : Put Electrical Data to Param

1. This process has 2 data/control flows :

Input data/control : selected_elect_data

Output data : param

2. Description :

(SRS_REQ_24000)

BEGIN

This capability shall put electrical data from read buffer through vector to memory address of read buffer

All the data as sequence as PCMLUT will put in to element of param structure.

END

3.2.2.5 Capability 2.5 : ArtBuf.com and ISR.PCM.com (non-developmental software)

The objective is to create data area for buffer in order to accept PCM_data from ACARD and create a controller to regulate the switching.

Process Specification (PSPEC) of capability 2.7 : ArtBuf.com and ISR.PCM.com

1. This process has 7 data/control flows :

Input data/control : adress_vector, PCM_data, read_buffer_vector, enable_bit

Output data/control: ISRPCM_address, selected_elect_data, ArtBuf_address

2. Description :

This capability is non-developmental-software.

ArtBuf has functions as follows :

- to create data area named PCM buffer1, PCM buffer2 and read buffer
- to receive PCM data stream from ARTISt card

ISRPCM has functions as follows :

- intercept on every incoming EOC sign
- to control DMA Acknowledge and DMA Request
- to regulate buffer destination of incoming PCM_data
- to switch PCM buffer into read buffer in order to be read by ARTISt CSCI

3.2.3 Capability 3: Translate to Engineering Data (SRS_REQ_30000)

Description :

The purpose of this process is to translate electrical data into engineering data using defined formulas.

The capability is broken down into 6 capabilities as follows:

- Get Local Parameter
- Convert ARINC
- Calculate Linear



**SOFTWARE REQUIREMENTS
SPECIFICATION
for Airborne Real Time Instrumentation System**

Document No.
EM/000/SRS/DD/003

Revision: 1

- Calculate Polynom
- Calculate Bit Mask
- Calculate Extended Parameter

The capability allows to activate and synchronize calculation of the data.
It is formalized the SA/RT diagram by two control processes (vertical bar). The following table explains the control process.

control		Activated Process				
		Convert ARINC (3.2p)	Calculate Linear (3.3p)	Calculate Polynom (3.4p)	Calculate Bit Mask (3.5p)	Calculate Extended Parameter (3.6p)
Cal_type	Cal_word					
1	1	0	1	0	0	0
2		0	0	1	0	0
3		0	0	0	1	0
4		0	0	0	0	1
1	3	1	1	0	0	0
2		1	0	1	0	0
3		0	0	0	0	0
4		0	0	0	0	0

note :
0 : not active 1 : active

Table : "Process activation Table of DFD/CFD 3"



**SOFTWARE REQUIREMENTS
SPECIFICATION
for Airborne Real Time Instrumentation System**

**Document No.
EM/000/SRS/DD/003
Revision: 1**

To see data flow and control flow of Translate to Engineering Data, it is depicted in below :

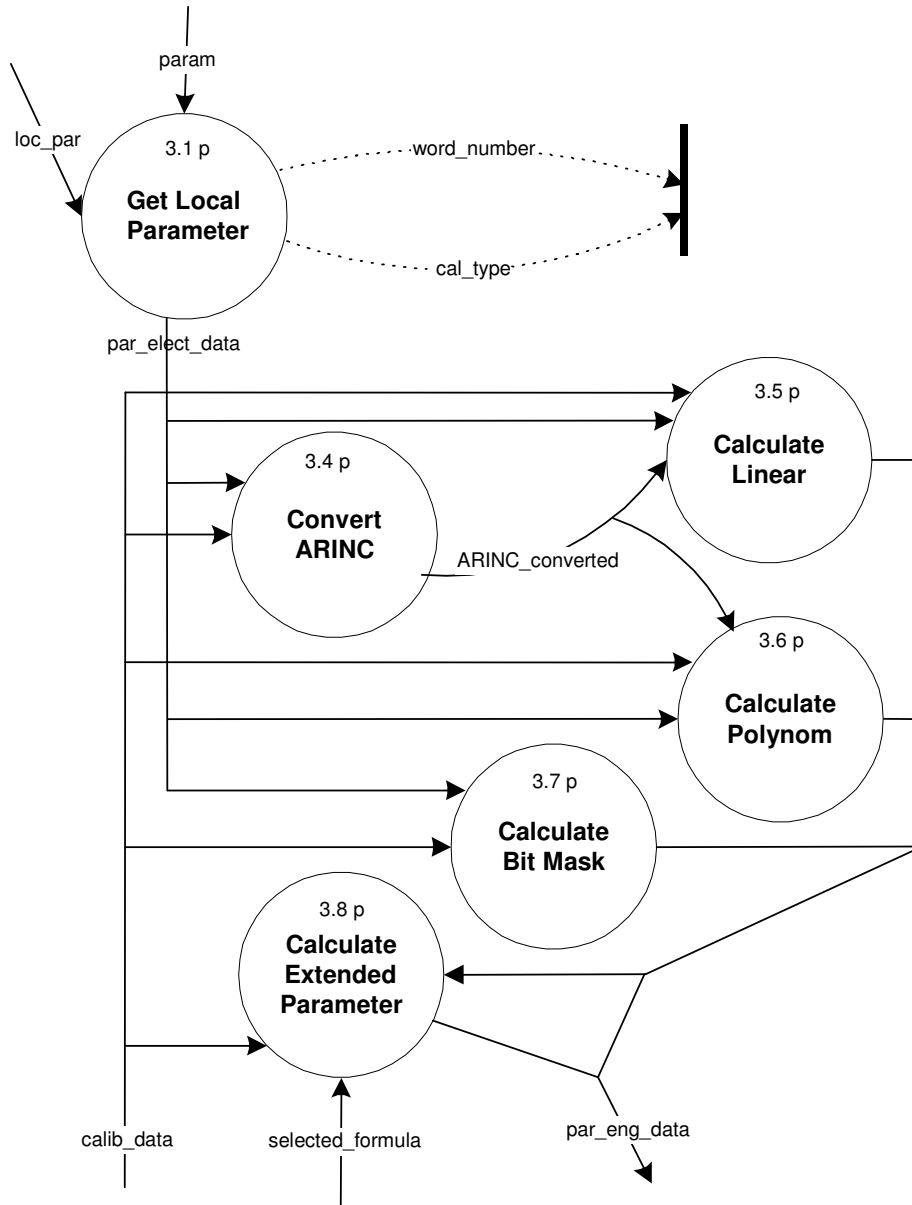

Figure 13 : "DFD/CFD 3 Translate to Engineering Data"



**SOFTWARE REQUIREMENTS
SPECIFICATION
for Airborne Real Time Instrumentation System**

**Document No.
EM/000/SRS/DD/003**

Revision: 1

The following table summarizes the data interfaces of the DFD/CFD 3 :

Name of Data	Source	Destination	Description	Data/Control Flow Type
word_number	Get Local Parameter	Bar	the number of word, 1=basic parameter, 2=ARINC parameter	internal data
cal_type	Get Local Parameter	Bar	the type of calibration. 1=linier calibration 2=polynom calibration 3=bit mask calibration 4=extended parameter	internal data
par_eng_data	Calculate Linear	Param (data storage)	engineering data of parameter resulted from calculation based on calibration data	Output data
	Calculate Polynom			
	Calculate Bit Mask	Calculate Extended Parameter		
	Calculate Extended Parameter	Param (data storage)		
par_elect_data	Get Local Parameter	Convert ARINC	set of data consists of 1 PCM word data and 3 PCM word data (ARINC-429). Electrical data with ARINC-429 format must be defined its data field because not all bits can be used for.	internal data
		Calculate Linear		
		Calculate Polynom		
		Calculate Bit Mask		
loc_par	Show Data	Get Local Parameter	parameter has been defined for being calculation to translate into engineering data parameter	input data
selected_formula	Initiate Program	Calculate Extended Parameter	Formula has been defined to the Extended parameter	Input Data
Param	Param (data storage)	Get Local Parameter	array of parameter behavior	Input data



**SOFTWARE REQUIREMENTS
SPECIFICATION
for Airborne Real Time Instrumentation System**

**Document No.
EM/000/SRS/DD/003**

Revision: 1

Name of Data	Source	Destination	Description	Data/Control Flow Type
calib_data	Initiate Program	Convert ARINC	set of calibration data	Input data
		Calculate Linear		
		Calculate Polynom		
		Calculate Bit Mask		
		Calculate Extended Parameter		
ARINC_converted	Convert ARINC	Calculate Linear	result of converted ARINC	Internal data
		Calculate Polynom		

Table 10 : "DFD/CFD 3 Interfaces"

3.2.3.1 Capability 3.1 : Get Local Parameter

The objective is to determine parameters as much as input from user.

Process Specification (PSPEC) of capability 3.1 : Get Local Parameter

1. This capability has 5 data/control flows

- Input data : loc_par, param;
- Output data/control : word_number, cal_type, par_elect_data

2. Description :

(SRS_REQ_31100)

BEGIN

This capability shall get par_cal, par_word, and par_elect_data according to parameters which is inputted from loc_par.

END

(SRS_REQ_31200)

BEGIN

Based on these local parameters, this capability will issue the electrical data of each parameter and send word_number and cal_type signal.

END



**SOFTWARE REQUIREMENTS
SPECIFICATION
for Airborne Real Time Instrumentation System**

**Document No.
EM/000/SRS/DD/003**

Revision: 1

3.2.3.2 Capability 3.4 : Convert ARINC

Process Specification (PSPEC) of capability 3.4 : Convert ARINC
Format ARINC is in 3 words (32 bits).

Generally ARINC data format is arranged of :

- label (1st bit – 8th bit)
label may be an identification of the parameter or receiving device address for alphanumeric data
- SDI (Source Destination Index) (9th bit, 10th bit)
SDI may be an identification of source or destination of data
- Data field (11th bit- 29th bit)
Data field may allocate from 11th bit as Least Significant Bit (LSB) , until 29th bit as Most Significant Bit (MSB)
- Sign Status Matrix (SSM) (30th bit, 31st bit)
SSM may be an identification of device condition, operational mode and validity of data
- Parity bit (32nd bit)
Parity may detect whether any failure of data

1.This capability has 3 data/control flows

- Input data : calib_data, par_elect_data
- Output data : ARINC_converted_result;

2. Description :

(SRS_REQ_34000)

BEGIN

This capability shall convert the ARINC data into i word data field according to the type of calibration. If the cal_type=linier, the ARINC data shall be converted with linier calculation. If the cal_type=polynom, the ARINC data shall be converted with polynom calculation.

END

3.2.3.3 Capability 3.5 : Calculate Linear

Process Specification (PSPEC) of capability 3.5 : Calculate Linear

1.This capability has 4 data/control flows

- Input data : par_elect_data, calib_data, ARINC_converted;
- Output data : par_eng_data;

2. Description :

(SRS_REQ_35000)

BEGIN

This capability translate par_elect_data (non ARINC) into par_eng_data by calculating with linear formula based on calib_data.

For ARINC data electrical data is taken from ARINC_converted.

END



**SOFTWARE REQUIREMENTS
SPECIFICATION
for Airborne Real Time Instrumentation System**

**Document No.
EM/000/SRS/DD/003**

Revision: 1

General formula : $Y = mX + C$
To find slope $m = (y_2 - y_1)/(x_2 - x_1)$
To find offset $C = y_1 - mx_1$
To calculate m and C, needs calib_data
Implementation : $par_eng_data = m(par_elect_data) + C$

3.2.3.4 Capability 3.6 : Calculate Polynom

Process Specification (PSPEC) of capability 3.6 : Calculate Polynom

1. This capability has 4 data/control flows

- Input data : par_elect_data, calib_data, ARINC_converted
- Output data : par_eng_data;

2. Description :

(SRS_REQ_36000)

BEGIN

This capability translates par_elect_data (for ARINC use ARINC_converted) into par_eng_data by calculating with polynom formula based on calib_data.

END

General formula : $y = C_0 + C_1 * x^1 + C_2 * x^2 + \dots + C_n * x^n$
 C_0, C_1, \dots, C_n is coefficient polynomial order n taken from calib_data.

Implementation :

$par_eng_data = C_0 + C_1 * par_elect_data + C_2 * par_elect_data^2 + \dots + C_n * par_elect_data^n$

3.2.3.5 Capability 3.7 : Calculate Bit Mask

Process Specification (PSPEC) of capability 3.7 : Calculate Bit Mask

1. This capability has 3 data flows (or controls)

- Input data : par_elect_data, calib_data
- Output data : par_eng_data;

2. Description :

(SRS_REQ_37000)

BEGIN

This capability translates par_elect_data into par_eng_data by calculating with Bit Mask formula based on calib_data.

END



**SOFTWARE REQUIREMENTS
SPECIFICATION
for Airborne Real Time Instrumentation System**

**Document No.
EM/000/SRS/DD/003**

Revision: 1

There is couple calib_data for each bit mask parameter (on-off parameter).

calib_data :

- bit mask data
- bit mask logic.

Bit Mask formula (BMF) : par_elect_data AND bit mask data

Implementation :

```
    If BMF != 0 then
    If bit mask logic is true then
        par_eng_data = 0
    Else
        par_eng_data = 1
    else
    If bit mask logic is true then
        par_eng_data = 1
    Else
        par_eng_data = 0
```

3.2.3.6 Capability 3.8 : Calculate Extended Parameter

Process Specification (PSPEC) of capability 3.8 : Calculate Extended Parameter

1.This capability has 4 data/control flows

- Input data : par_eng_data, calib_data, selected_formula
- Output data : par_eng_data;

2. Description :

(SRS_REQ_38000)

BEGIN

This capability calculate Extended Parameter based on formula in formula_file.

END

3.2.4 Capability 4: Show Electrical/Engineering Data

Description :

This capability show electrical data or engineering data. Its means can show in display/monitor in table, graphic, mixed (table and graphic), and xplot (graphic between 2 parameters) mode. And can also print the parameter to the printer.

The capability is broken down into 5 capabilities as follows:

- Display Table
- Display Graphic
- Display Mixed
- Display XPlot
- Print Parameter Data



SOFTWARE REQUIREMENTS SPECIFICATION
for Airborne Real Time Instrumentation System

Document No.
EM/000/SRS/DD/003

Revision: 1

The DFD/CFD 4 : "Show Electrical/Engineering Data" is depicted as follows :

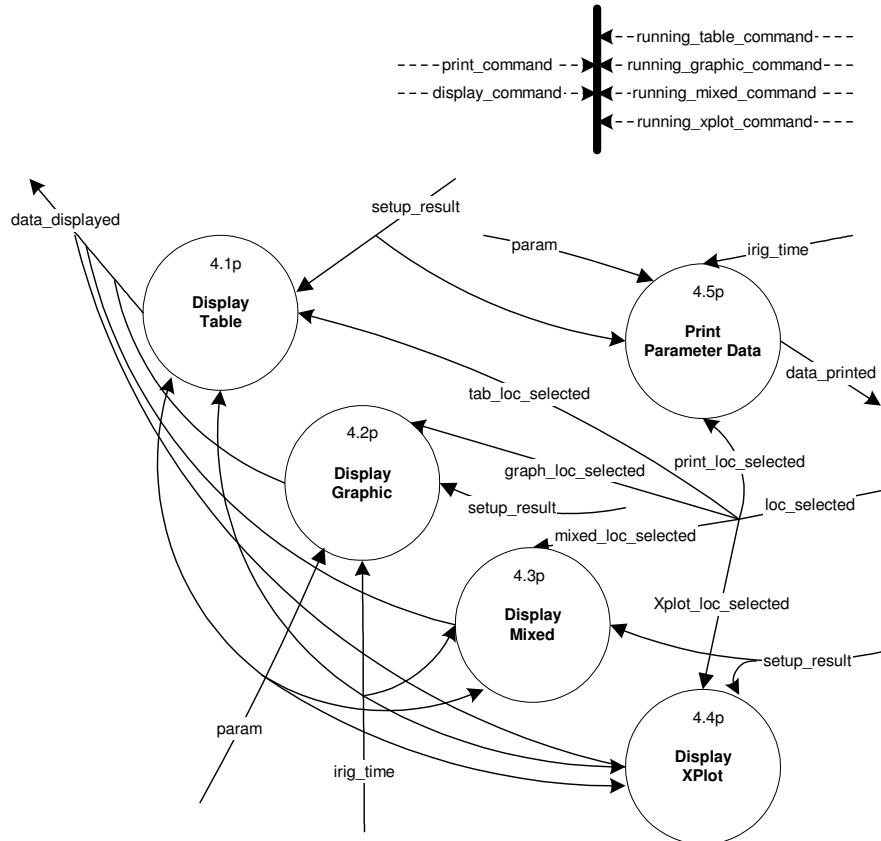

Figure 14 : "DFD/CFD 4 Show Electrical/Engineering Data"



**SOFTWARE REQUIREMENTS
SPECIFICATION
for Airborne Real Time Instrumentation System**

**Document No.
EM/000/SRS/DD/003**

Revision: 1

The following table summarizes the data interfaces of the DFD/CFD 4 :

Name of Data	Source	Destination	Description	Data/Control Flow Type
param	Param (data storage)	Print Parameter Data	all attribute of param	Input data
		Display Table		
		Display Graphic		
print_command	MMIMS	Bar	command from user for start or stop print- ing	input control
display_command	MMIMS	Bar	command from user for display elect or eng	input control
running_command	MMIMS	Bar	command from user for display table, graphic, mixed, or Xplot	input control
data_printed (IRS_REQ_31000)	Print Parame- ter Data	APRINTER	set of data to be printed.	Output data
setup_result	Initiate Pro- gram	Display Table	result of setup presen- tation to be displayed and/or printed	Input data
		Display Graphic		
data_displayed (IRS_REQ_23000)	Display Graphic	MMIMS	set of data to be dis- played.	Output data
	Display Table			
	Display Mixed			
	Display XPlot			
graph_selected	Initiate Pro- gram	Display Graphic	parameter determined for graphical display	Input Data
tab_selected	Initiate Pro- gram	Display Table	parameter determined for table display	Input Data
printer_selected	Initiate Pro- gram	Print Parameter Data	parameter determined to be printed	Input Data

Table 11 : "DFD/CFD 4 Interfaces"



**SOFTWARE REQUIREMENTS
SPECIFICATION
for Airborne Real Time Instrumentation System**

**Document No.
EM/000/SRS/DD/003**

Revision: 1

The following State Transition Diagram (STD) describe the behavior of ARTISr CSCI in the running mode:

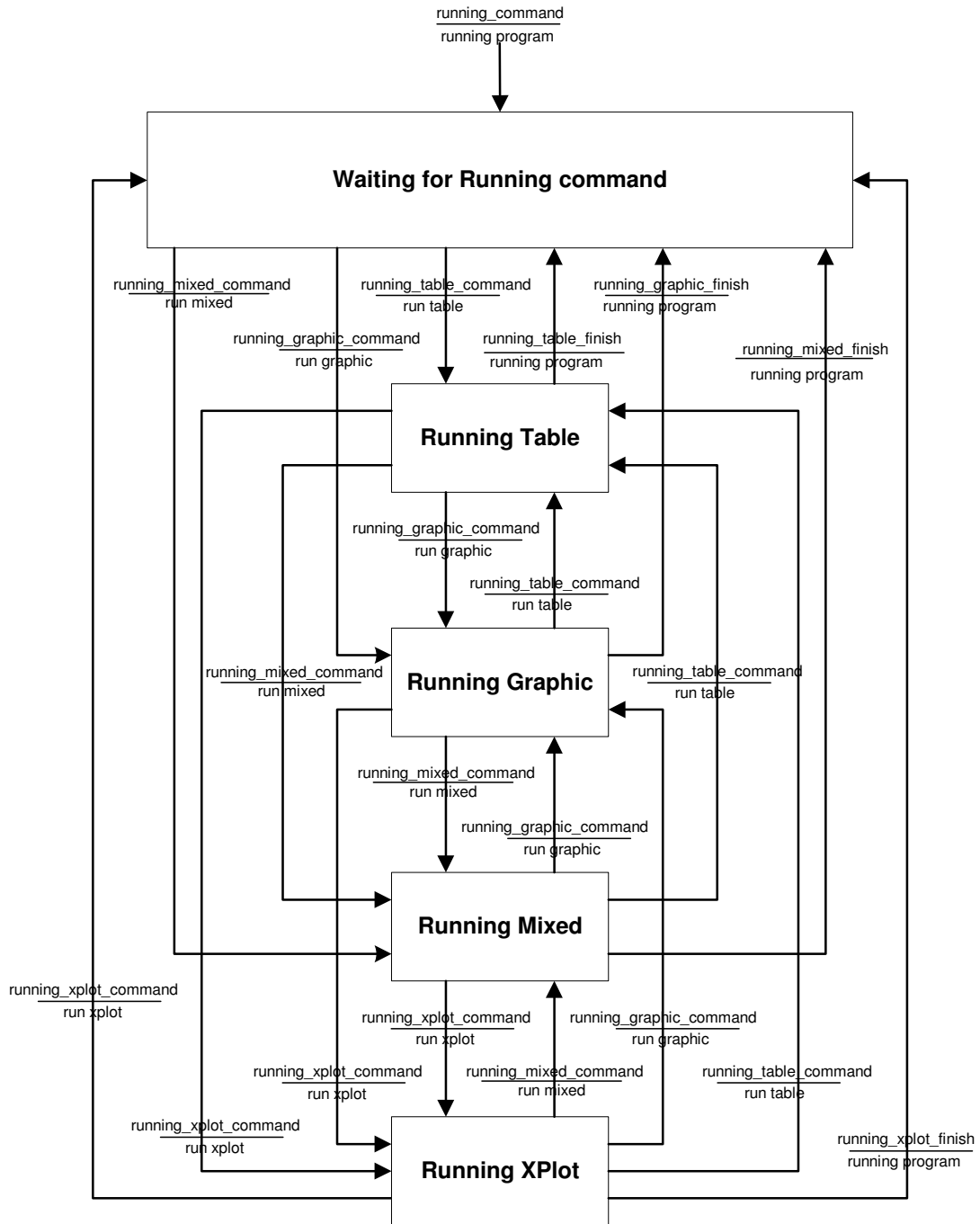

Figure 15 : "State Transition Diagram of ARTISr in the Running Mode"



**SOFTWARE REQUIREMENTS
SPECIFICATION
for Airborne Real Time Instrumentation System**

**Document No.
EM/000/SRS/DD/003**

Revision: 1

This capability represents four control functions according to SA/RT model (vertical bar on diagram).

Control	Process				
	Display Table	Display Graphic	Display Mixed	Display XPlot	Print Parameter Data
running_table_command	1	0	0	0	0
running_graphic_command	0	1	0	0	0
running_mixed_command	0	0	1	0	0
running_xplot_command	0	0	0	1	0
print_command	0	0	0	0	1

Control	Process				
	Display Table	Display Graphic	Display Mixed	Display XPlot	Print Parameter Data
display_command					
0 (elect)	1	1	1	1	1
1 (eng)	1	1	1	1	1

note : 0 : not activated 1 : activated dc : don't care

Table 12 : "Process activation table of DFD/CFD 4"

3.2.4.1 Capability 4.1 : Display Table

Process Specification (PSPEC) of capability 4.1: Display Table

1.This capability has 7 data flows (or controls)

- Input data : setup_result, table_selected, graph_table_mode, param, irig_time;
- Output data : data_displayed, eng_elect_mode;

2. Description :

(SRS_REQ_41100)

BEGIN

This capability shall display parameters in table mode.

If the running_command is table, then this capability will display the parameters on table mode based on tab_loc_selected either electrical or engineering data according to the setup_result. The maximum parameters that can be displayed are 8 parameters.

END



**SOFTWARE REQUIREMENTS
SPECIFICATION
for Airborne Real Time Instrumentation System**

Document No.
EM/000/SRS/DD/003
Revision: 1

3.2.4.2 Capability 4.2 : Display Graphic

Process Specification (PSPEC) of capability 4.2: Display Graphic

1.This capability has 7 data flows (or controls)

- Input data : setup_result, graphic_selected, graph_table_mode, param, irig_time;
- Output data : data_displayed, eng_elect_mode;

2. Description :

(SRS_REQ_42100)

BEGIN

This capability shall display parameters in graphic mode.

If the running_command is graphic, then this capability will display the parameters on graphic mode based on graph_loc_selected either electrical or engineering data according to the setup_result. The maximum parameters that can be displayed are 4 parameters.

END

3.2.4.3 Capability 4.3 : Display Mixed

Process Specification (PSPEC) of capability 4.3: Display Mixed

1.This capability has 7 data flows (or controls)

- Input data : setup_result, mixed_loc_selected, graph_table_mode, param, irig_time;
- Output data : data_displayed, eng_elect_mode;

2. Description :

(SRS_REQ_43100)

BEGIN

This capability will display the parameters on mixed mode (table and graphic mode) based on mixed_loc_selected either electrical or engineering data according to the setup_result. The maximum parameters that can be displayed are 2 parameters in graphic mode and 10 parameters in table mode.

END

3.2.4.4 Capability 4.4 : Display XPlot

Process Specification (PSPEC) of capability 4.4: Display XPlot

1.This capability has 7 data flows (or controls)

- Input data : setup_result, xplot_loc_selected, graph_table_mode, param, irig_time;
- Output data : data_displayed, eng_elect_mode;



**SOFTWARE REQUIREMENTS
SPECIFICATION
for Airborne Real Time Instrumentation System**

**Document No.
EM/000/SRS/DD/003**

Revision: 1

2. Description :

(SRS_REQ_44100)

BEGIN

This capability shall display the parameters on xplot mode based on xplot_loc_selected either electrical or engineering data according to the setup_result. The maximum parameters that can be displayed are 4 parameters in 2 xplot mode and 10 parameters in table mode.

END

3.2.4.5 Capability 4.5 : Print Parameter Data

Process Specification (PSPEC) of capability 4.5 : Print Parameter Data

1.This capability has 6 data flows (or controls)

- Input data : print_loc_selected, setup_result, eng_elect_mode, param, irig_time
- Output data : data_printed;

2. Description :

(SRS_REQ_43000)

BEGIN

This capability shall print the parameters based print_loc_selected in engineering or electrical depend on display_command. The maximum number of parameters can be printed are 16 parameters.

END

3.2.5 Capability 5 : Record Electrical/Engineering Data

Process Specification (PSPEC) of capability 5 : Record Electrical/Engineering Data

1.This capability has 5 data flows (or controls)

- Input data : record_file_name, param, calib_data;
- Output data : recorded_files, message;

2. Description :

(SRS_REQ_51000)

BEGIN

This capability shall record the electrical data of parameters (all parameters) in binary format together with given name of file (record_file_name). The recorded is began if the record_command to start the recorded is occurred and finished if the record_command to stop the recorded is occurred. If any errors occur during recording, the capability shall provide message. Recording electrical data is in header file and data file according to the record_heav_file (IRS_REQ_42100) and record_val_file (IRS_REQ_42200).

END



**SOFTWARE REQUIREMENTS
SPECIFICATION**
for Airborne Real Time Instrumentation System

Document No.
EM/000/SRS/DD/003

Revision: 1

(SRS_REQ_51000)

BEGIN

This capability shall record the engineering data (based on selected parameters) in text format together with given name of file (record_file_name). The maximum parameters can be recorded in engineering are 30 parameters. The recording is begun if the record_command to start the recording is occurred and finished if the record_command to stop the recording is occurred. If any errors occur during recording, the capability shall provide message. Recording engineering data is according to the record_eng_file (IRS_REQ_42300).

END



**SOFTWARE REQUIREMENTS
SPECIFICATION
for Airborne Real Time Instrumentation System**

**Document No.
EM/000/SRS/DD/003**

Revision: 1

3.3 CSCI internal interfaces

See paragraph 3.4.2

3.4 CSCI data element requirements

3.4.1 External data

The external data concern to the external interfaces of the CSCI ARTIST. These data are described in the Table 1 on paragraph 3.1 and IRS [5].

3.4.2 Internal data

The internal data concern to the internal data flow of the CSCI ARTIST are described in Table 8 below :

Data Requirement	Data Element	Value	Unit Of Value	Type Of Value	Description
setup_result (SRS_REQ_54000)=[dismod_result+framred_result+numsym_result]	dismod_result (SRS_REQ_54100)	112	--	integer	result of display mode. Defined as : 1=elect; 2=eng;
	framred_result (SRS_REQ_54200)	112	--	integer	result of framred mode. Defined as : 1=with framred; 2=without framred
	numsym_result (SRS_REQ_54300)	112	--	integer	result of numsym mode. Defined as : 1=par_name; 2=par_sym
irigtime (SRS_REQ_55000)	hour+minute+second +milisecond	--	--	--	Represent of IRIG TIME used.
	hour	0..23	hour	integer	Represent of irig hour
	minute	0..59	minute	integer	Represent of irig minute
	second	0..59	second	integer	Represent of irig second
	milisecond	0..999	msec	integer	Represent of irig mili second



**SOFTWARE REQUIREMENTS
SPECIFICATION
for Airborne Real Time Instrumentation System**

**Document No.
EM/000/SRS/DD/003**

Revision: 1

cont'd

Data Requirement	Data Element	Value	Unit Of Value	Type Of Value	Description
param (SRS_REQ_56000)	param_id (IRS_REQ_23110)	--	--	--	set of parameter identification. all data elements
	par_pcmpos (SRS_REQ_56100)	integer number	--	integer	Pcm position of parameter.
	par_pol (SRS_REQ_56200)	1 2	--	byte	Polarity of parameter. Defined as : 1=unipolar; 2=bipolar.
	par_cal (SRS_REQ_56300)	1 2 3 4	--	byte	Calibration type of parameter. Defined as : 1=linear calibration; 2=polynom calibration; 3=bit mask calibration; 4=Extended parameter.
	par_word (SRS_REQ_56400)	1 3	--	byte	Number of word. Defined as : 1=parameter with 1 word 2=parameter with 3 word (ARINC-429).
	par_com (SRS_REQ_56500)	1 2 3	--	byte	Commutation of parameter. Defined as : 1=normal repetition; 2=with commutation; 3=super commutation;
	par_min (SRS_REQ_56550)	integer number	--	integer	Minimum range of parameter.
	par_max (SRS_REQ_56600)	integer number	--	integer	Maximum range of parameter.
	par_numcal (SRS_REQ_56650)	1{0..9} 3	--	integer	Number of calibration.
	par_calptr (SRS_REQ_56700)	1{0..9} 5	--	integer	Vector to calibration buffer.
	par_mask (SRS_REQ_56750)	integer number	--	integer	mask buffer.
	par_electptr (SRS_REQ_56800)	1{0..9} 5	--	integer	Vector to electrical data buffer.
	par_elect_data (SRS_REQ_56850)	Long number	--	long	electrical data of parameter
par_eng_data (SRS_REQ_56900)	Float number	--	Float	Engineering data of the parameter	



**SOFTWARE REQUIREMENTS
SPECIFICATION
for Airborne Real Time Instrumentation System**

**Document No.
EM/000/SRS/DD/003**

Revision: 1

cont'd

Data Requirement	Data Element	Value	Unit Of Value	Type Of Value	Description
calib_data (SRS_REQ_57000)	--	float number	--	float	Set of calibration data
num_of_parameter (SRS_REQ_58000)	--	1{0..9} 3	--	integer	Number of parameter.
De-fault_parameter_setup (SRS_REQ_59000)	dismod_default (SRS_REQ_59100)	1 2	--	integer	default of display mode. Defined as : 1=elect; 2=eng;
	framred_default (SRS_REQ_59200)	1 2	--	integer	default of framred mode. Defined as : 1=with framred; 2=without framred
	irig_default (SRS_REQ_59300)	1 2 3 4 5	--	integer	default of irigtime used. Defined as : 1=Teledyne separated; 2=Teledyne compact; 3=Aydin vector separated; 4=Aydin vector compact; 5=Generated by computer;
	numsym_default (SRS_REQ_59400)	1 2	--	integer	default of numsym mode. Defined as : 1=par_name; 2=par_sym
Irigtime_parameter (SRS_REQ_60000)	IrigTimePtr (SRS_REQ_60100)	1{0..9} n	--	integer	Vector to Irig Time.
	PCMTimePtr (SRS_REQ_60200)	1{0..9} n	--	integer	Vector to PCM Time.
	PilotPtr (SRS_REQ_60300)	1{0..9} n	--	integer	Vector to Pilot Time.
	FormatPtr (SRS_REQ_60400)	1{0..9} n	--	integer	Vector to Format Time.
selected_elect_data (SRS_REQ_61000)	--	0..4095	digit	integer	Electrical data in sequential based on PCMLUT from memory read buffer
ARINC_converted (SRS_REQ_62000)	--	long number	--	long	data field of ARINC-429 converted.



**SOFTWARE REQUIREMENTS
SPECIFICATION**
for Airborne Real Time Instrumentation System

Document No.
EM/000/SRS/DD/003

Revision: 1

cont'd

Data Requirement	Data Element	Value	Unit Of Value	Type Of Value	Description
Tmp_vector (SRS_REQ_65000)	--	integer number	--	integer	Temporarily vector
ArtBuf_address (SRS_REQ_66000)	--	integer number	--	integer	location of ArtBuf.com while it is resident in memory RAM
buffer_addresses (SRS_REQ_67000)	--	integer number	--	integer	addresses of PCM buffer1, PCM buffer2 , read buffer
ISRPCM_address (SRS_REQ_68000)	--	integer number	--	integer	location of ISRPCM.com while it is resident in memory RAM
adress_vector (SRS_REQ_69000)	--	integer number	--	integer	vector which contains of first address PCM Buffer1 and first address PCM buffer 2
isr_param (SRS_REQ_70000)	--	integer number	--	integer	converted address ar-ranges of segment and offset of ISRPCM.com
read_buffer_vector (SRS_REQ_71000)	--	integer number	--	integer	vector to first address read buffer



**SOFTWARE REQUIREMENTS
SPECIFICATION
for Airborne Real Time Instrumentation System**

**Document No.
EM/000/SRS/DD/003**

Revision: 1

cont'd

Data Requirement	Data Element	Value	Unit Of Value	Type Of Value	Description
loc_selected (SRS_REQ_74000)	tab_loc_selected (SRS_REQ_74100)	0..300	--	integer	local parameters selected to be displayed on table mode.
	graph_loc_selected (SRS_REQ_74200)	0..300	--	integer	local parameters selected to be displayed on graphic mode.
	mixed_loc_selected (SRS_REQ_74300)	0..300	--	integer	local parameters selected to be displayed on mixed mode.
	print_loc_selected (SRS_REQ_74400)	0..300	--	integer	local parameters selected to be printed.
	xplot_loc_selected (SRS_REQ_74500)	0..300	--	integer	local parameters selected to be displayed on xplot mode.
	rec_eng_loc_selected (SRS_REQ_74600)	0..300	--	integer	local parameters selected to be recorded on engineering data.
loc_par (SRS_REQ_75000)	--	0..300	--	integer	parameter has been defined for being calculation to translate into engineering data
selected_formula (SRS_REQ_76000)	--	1{alpha nu- meric} 30	--	string	Formula used for Extended parameter

Table 13 : “Data Requirement Of Internal Data”

3.5 Adaptation requirement

3.5.1 Installation-dependent data

The ARTISt CSCI shall use the adaptation data as follow:

- ISRPCM.COM
- ARTBUF.COM

3.5.2 Operational parameters

The ARTISt CSCI shall use the operational parameters as follow:

- configuration file (artist.ini)
- calibration file (*.des)
- extended file (*.fml) if the extended parameter is available in the calibration file.



**SOFTWARE REQUIREMENTS
SPECIFICATION
for Airborne Real Time Instrumentation System**

Document No.
EM/000/SRS/DD/003
Revision: 1

3.6 Sizing and Timing requirements

This information describes the amount of processing time allocated to the CSCI and the memory required for the CSCI.

3.6.1 Sizing requirements

3.6.1.1 The Size of PCM Data

Source of data is incoming from On Board Data Acquisition (OBDAS).
The data transmitted by OBDAS, will be configured in Pulse Code Modulation (PCM)
The following pictures depict PCM data arranged within OBDAS and the output generated from OBDAS.

The data has following subject :

- Data source : OBDAS
- Data format : PCM data stream
(OBDAS generates a serial PCM bit stream output)
- Bit rate (optimum) : 128 kbps (kilo bit per second)
(maximum) : 512 kbps
When frame size incoming from OBDAS is smaller than 64x48, then bit rate optimum will increase.
Bit rate specification from OBDAS is 128 kbps.
- PCM data packet (frame size) : (64 x 48) word = 3072 words
OBDAS acquires signal from sensors then decode into PCM data packet. The size of PCM data packet (frame size) is **64** in length and **48** in depth.
After PCM frame size has been arranged, OBDAS will transmit PCM frame in a *serial PCM bit stream* output.
One serial PCM bit stream is 12 bit data (1 word).

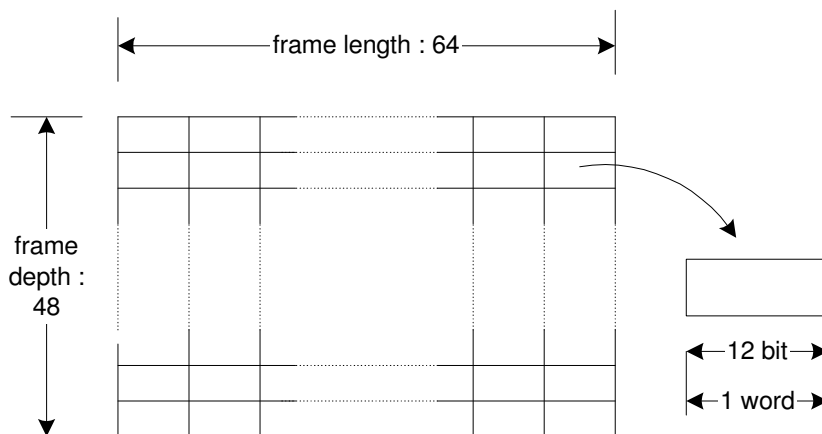

Figure 16 : "Size of PCM Data per Frame"



**SOFTWARE REQUIREMENTS
SPECIFICATION
for Airborne Real Time Instrumentation System**

**Document No.
EM/000/SRS/DD/003**

Revision: 1

Note :

- Frame depth and frame length which is incoming from OBDAS may be variation.
- Size 64x48 is OBDAS maximum size for ARTISt within current condition.
- If frame depth and length has been decreased, then it will enlarge speed of frame (frame rate).
- So, frame rate is influenced by size frame incoming.

3.6.1.2 The Size of Hard Disk

The following memory of CPU are available in the system :

- RAM 16 MBytes
- Harddisk : 850 Mbytes

CPU contains Pentium based.

Assumption : Total safety parameters which are needed during flight test are 75 parameters.

If all safety parameters (*in every frame*) have to be processed, then the size will be as follows :

All safety parameters are ARINC parameter within 3 words data.

So, maximum PCM words : 75 x 3 = 225 PCM words

Each parameter to be recorded needs : 16 bits = 2 bytes

For all PCM words (225) need : 225 x 2 bytes = 450 bytes

Because every incoming frame spends 288 ms then it spends:

$$\begin{aligned} \approx 450 \times (1000 \div 288) &\approx \mathbf{1562} \text{ bytes / 1000 ms} \\ &\approx \mathbf{1562} \text{ bytes / second} \end{aligned}$$

If the test is performed during 1 hour (3600 seconds) then needs : (1562 x 3600) bytes = 5623200 bytes.
 $\approx 5,6$ Mega bytes

According for those assumption above, therefore CSCI ARTISt shall use 5,6 (≈ 6) Mbytes of harddisk.

For 2 hours, ARTISt needs free space around 12 Mbytes of harddisk, and so on.

Conclusion :

The ARTISt CSCI may use up the following amount of these resources :

- 4 % of the RAM CPU
ARTISt run in DOS, maximum needs is 640 Kbytes memory.
Maximum used : 640 Kbytes / 16 Mbytes = 0.04 %
- Minimal free space available every 2 hours test : 12 Mega bytes

3.6.2 Timing of PCM Data

PCM data is sent to memory PC in stream format

OBDAS may transmit as much one frame PCM data in specific time. It began with start of frame and will be ended by end of frame signal. This signal must be caught by ARTISt.

ARTISt sends part of this frame (only which named in PCMLUT) to PC memory.

Time which is needed for sending every part of frame PCM data, is equal with time requirement from OBDAS.

For the current condition, OBDAS sends every PCM data in 64x48 frame size at described below :

- Total bit per frame : (64 x 48 x 12) bit = 36864 bit

- Frame rate : $\frac{\text{bit rate}}{\text{Total bit per frame}} = \frac{128 \text{ kilo bit per second}}{36864 \text{ bit}} = 3.472 \text{ per second}$



**SOFTWARE REQUIREMENTS
SPECIFICATION
for Airborne Real Time Instrumentation System**

Document No.
EM/000/SRS/DD/003
Revision: 1

It can be said that OBDAS will generate PCM data about **3.472 frame per second**.
Every frame need 288 ms to be accessed.

From figure 17 ,

- t 1 : time for first frame
- t 2 : time for second frame
- t 3 : time for third frame
- t 4 : time for forth frame
- t 1 = t 2 = t 3 = t 4 = 288 ms

ARTIS_t card shall issues first frame after the second frame incoming completely.

So, ARTIS_t CSCI needs delay time from the beginning t 2 until at the end t 2 (during t 2), to perform execution of the first frame.

During t 3 ARTIS_t will be processing the second frame.

During t 4 ARTIS_t will be processing the third frame and so on.

ARTIS_t CSCI should be able to perform all capabilities to the every frame maximum in 288 ms, because the next frame will be incoming.

The following figure describes 4 incoming frames :

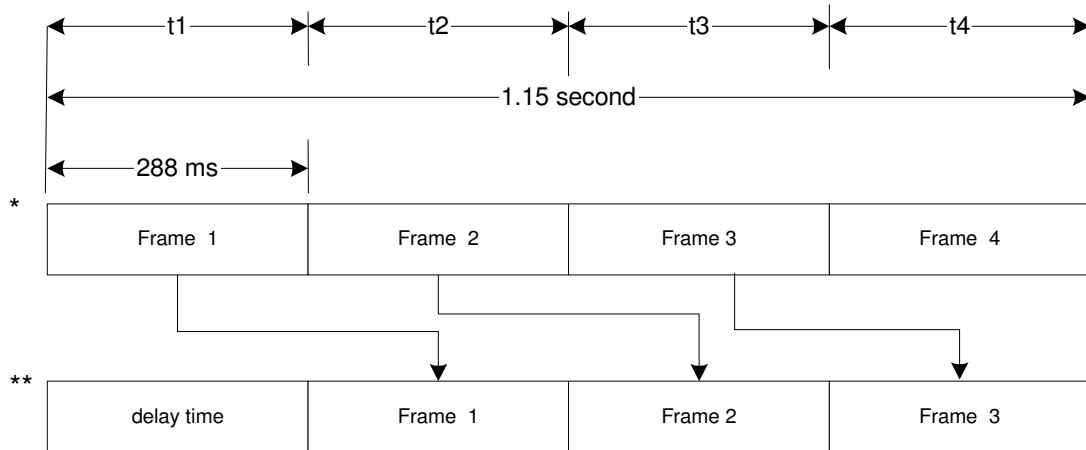

- * : incoming frame
- ** : time to process incoming frame

Figure 17 : "Frame Acquisition Time"

Frame size : 64 x 48 = 3072 PCM word

ARTIS_t driver module (the NDS files) uses double buffer method.

Description of double buffer way :

At the first time, both buffers will no contain. For every frame incoming, the first PCM data frame (signed by start of frame) shall fill to PCM buffer 1 (see paragraph 3.2.2.2 and paragraph 3.2.2.3), until the end of PCM data frame (signed by end of frame) has come. It is carrying out for one frame time about 288 milieu second.

ARTIS_t has delay time during this condition.

When PCM buffer2 in PC memory is being filled by PCM data, the ingredients of PCM buffer 1 will be read by Read buffer. This condition may be happened in the opposite.

Then, ARTIS_t CSCI has to read data from Read buffer.



**SOFTWARE REQUIREMENTS
SPECIFICATION
for Airborne Real Time Instrumentation System**

**Document No.
EM/000/SRS/DD/003**

Revision: 1

PCM word position is equal to :
 $(Fn + 1) \times Fl + Wn$

whereas :

Fn : frame number
Fl : frame length
Wn : word number

3.7 Safety requirements

Not Applicable. There is no potential hazard to personnel, property and the physical environment.

3.8 Security requirements

Not Applicable. There is no security requirements which are handled by ARTIS_t CSCI. It will be handled manually to determine who has a permission to access the ARTIS_t.

3.9 Design constraints

Target computer : minimum PC AT-486 based (SRS_REQ_91000)
Programming language : C language (SRS_REQ_92000)
Hardware required :

- ARTIS_t Card (SRS_REQ_93100)
- OBDAS (SRS_REQ_94000)
- Dot matrix printer Epson LQ series (SRS_REQ_93200)
- ARTIS_t Cable(SRS_REQ_93300)
- Harddisk min 50 MB(SRS_REQ_93400)

Operating system : DOS minimum 4.00 (SRS_REQ_93500)

3.10 Software quality factors

ARTIS_t CSCI may comply to the following quality factors :

- Portability
ARTIS_t can be easily moved (moveable).
- Maintainability
- Flexibility
ARTIS_t can run on PC within processor manufactured by either intel or AMD or IBM processor.
The casing model of PC does not influence ARTIS_t performance.

3.11 Human performances/human engineering requirements

To operate ARTIS_t on Aircraft, it should be a flight test engineer who has trained specially by DLP-FTC.



**SOFTWARE REQUIREMENTS
SPECIFICATION
for Airborne Real Time Instrumentation System**

**Document No.
EM/000/SRS/DD/003**

Revision: 1

3.12 Requirements traceability

This paragraph shall describe a mapping of allocation of the CSCI ARTIS requirements.

REQUIREMENT		Allocation reference	Description
Source	allocated		
System shall initiate/Setup Program	SRS_REQ_11000	3.2.1.1	Initiate system configuration from config_file
	SRS_REQ_54000	3.4.2	set of result to setup program
	SRS_REQ_55000	3.4.2	Represent of irig time used
	SRS_REQ_56000	3.4.2	set of parameters attributes
	SRS_REQ_14500	3.2.1.4.5	capability Compress Vector
	SRS_REQ_14600	3.2.1.4.6	capability Update Parameter Vector
	SRS_REQ_65000	3.4.2	temporary vector
	SRS_REQ_57000	3.4.2	set of calibration data
	SRS_REQ_59000	3.4.2	Parameters to setup program from config file
	IRS_REQ_41100	3.6.2	set of configuration program
	SRS_REQ_12100	3.2.1.2.1	Define Global Parameter
	SRS_REQ_12200	3.2.1.2.2	Select Local Parameter
	IRS_REQ_41200	3.6.2	set of calibration data
	IRS_REQ_22100	3.4.2	Calibration file name
	SRS_REQ_13000	3.2.1.3	setup presentation
	SRS_REQ_13100	3.2.1.3.1	setup irig time
	IRS_REQ_22230	3.4.2	irig time mode
	SRS_REQ_59300	3.4.2	default of irig time used
	SRS_REQ_55000	3.4.2	Represent of IRIG TIME used.
	SRS_REQ_13200	3.2.1.3.2	setup dismod
	IRS_REQ_22210	3.4.2	display mode
	SRS_REQ_59100	3.4.2	default of display mode
	SRS_REQ_13300	3.2.1.3.3	setup framred
	IRS_REQ_22220	3.4.2	frame reduction mode
	SRS_REQ_59200	3.4.2	default of frame reduction mode
	SRS_REQ_13400	3.2.1.3.4	setup numsym
	IRS_REQ_22240	3.4.2	numsym mode
	SRS_REQ_59400	3.4	default of numsym mode
	IRS_REQ_22200	3.4.2	parameters to setup program
	SRS_REQ_14000	3.2.1.4	generate PCMLUT
	IRS_REQ_12000	3.3.2	system requires PCM data to ACARD by sending PCMLUT
	SRS_REQ_14100	3.2.1.4.1	Create array vector of parameter
SRS_REQ_14200	3.2.1.4.2	capability Append System Vector	
SRS_REQ_14300	3.2.1.4.3	capability Append Vector of Multiword Parameter	



**SOFTWARE REQUIREMENTS
SPECIFICATION
for Airborne Real Time Instrumentation System**

**Document No.
EM/000/SRS/DD/003**

Revision: 1

cont'd

REQUIREMENT		Allocation refer- ence	Description
source	allocated		
	SRS_REQ_14400	3.2.1.4.4	capability Sort Vector
	SRS_REQ_56800	3.4.2	vector to electrical data
	SRS_REQ_69000	3.4.2	vector which contains of first address PCM Buffer1 and first address PCM buffer 2
	SRS_REQ_71000	3.4.2	vector to first address read buffer
	SRS_REQ_24000	3.2.2.5	Put Electrical Data to Param
	SRS_REQ_15100	3.2.1.5	Load formula file from DMS
	IRS_REQ_41300	3.6.2	File contains formulas used for derivative parameter
	IRS_REQ_22800	3.4.2	Arithmetic operation formula for determining derivative parameter
	SRS_REQ_76000	3.4.2	Formula used for Extended parameter
	IRS_REQ_22400	3.4.2	This data flow carries selection of parameters to be displayed or printed
	SRS_REQ_74000	3.4.2	Entry parameter for displaying and printing
	SRS_REQ_75000	3.4.2	parameter has been defined for being calculation to translate into engineering data
	SRS_REQ_16100	3.2.1.6.1	print aircraft configuration
	IRS_REQ_32000	3.5.2	aircraft configuration will be printed
	SRS_REQ_16200	3.2.1.6.2	record aircraft configuration
	IRS_REQ_21400	3.4.2	command from user to set up program configuration
	IRS_REQ_21410	3.4.2	command from user to set up Aircraft configuration
	IRS_REQ_21420	3.4.2	command from user to set up configuration of global parameter
	IRS_REQ_21430	3.4.2	command from user to set up configuration of local parameters
	IRS_REQ_21440	3.4.2	command from user to set up configuration of data presentation
	IRS_REQ_21500	3.4.2	command from user to finish setting up
	IRS_REQ_21800	3.4.2	command from user for print the ac_config
	IRS_REQ_21900	3.4.2	command from user for record the ac_config
	IRS_REQ_22400	3.4.2	selection of parameters to be displayed, printed, or recorded
	IRS_REQ_22500	3.4.2	name of record_file
	IRS_REQ_22600	3.4.2	Configuration of aircraft
	IRS_REQ_22700	3.4.2	Name of aircraft configuration file to be recorded
	IRS_REQ_23000	3.4.2	Set of data will be displayed



**SOFTWARE REQUIREMENTS
SPECIFICATION
for Airborne Real Time Instrumentation System**

**Document No.
EM/000/SRS/DD/003**

Revision: 1

cont'd

REQUIREMENT		Allocation refer- ence	Description
source	allocated		
System shall Collect Electrical Data from ACARD	SRS_REQ_20000	3.2.2	Collect Electrical Data from ACARD
	SRS_REQ_61000	3.4.2	Electrical data according to address chosen and total parameter needed
	IRS_REQ_11000	3.3.2	PCM data in stream format
	SRS_REQ_73000	3.4.2	enable bit data flow
	SRS_REQ_21000	3.2.2.2	find buffer location
	SRS_REQ_67000	3.4.2	buffer address data flow
	SRS_REQ_68000	3.4.2	location of ISRPCM.com while it is resident in memory RAM
	SRS_REQ_22000	3.2.2.3	Find ISRPCM
	SRS_REQ_70000	3.4.2	converted address arranges of segment and offset of ISRPCM.com
	SRS_REQ_23000	3.2.2.3	Store Address Buffer to ISRPCM
	SRS_REQ_24000	3.2.2.4	Put electrical data to param
	SRS_REQ_71000	3.4.2	vector to first address read buffer
	System shall process electrical data into engineering data.	SRS_REQ_30000	3.2.3
SRS_REQ_31100		3.2.3.1	get par_cal, par_word, and par_elect_data
SRS_REQ_31200		3.2.3.1	issue the electrical data of each parameter and send word_number and cal_type signal
SRS_REQ_56300		3.4	calibration type of parameter
SRS_REQ_56400		3.4	number of word
SRS_REQ_56850		3.4	vector to electrical data
SRS_REQ_34000		3.2.3.4	convert arinc
SRS_REQ_62000		3.4	linear converted
SRS_REQ_63000		3.4	polynom converted
SRS_REQ_35000		3.2.3.5	calculate linear
SRS_REQ_36000		3.2.3.6	calculate polynom
SRS_REQ_37000		3.2.3.7	calculate bit mask
SRS_REQ_38000		3.2.3.8	calculate Extended Parameter
SRS_REQ_56900	3.4	vector to calibration data	



**SOFTWARE REQUIREMENTS
SPECIFICATION
for Airborne Real Time Instrumentation System**

**Document No.
EM/000/SRS/DD/003**

Revision: 1

cont'd

REQUIREMENT		Allocation refer- ence	Description
source	allocated		
System shall Show Electrical/Engineering Data and Save Electrical Data	SRS_REQ_41100	3.2.4.1	display paramaters in table mode
	SRS_REQ_42100	3.2.4.2	display paramaters in graphic mode
	SRS_REQ_43100	3.2.4.3	display paramaters in mixed mode
	SRS_REQ_44100	3.2.4.4	display paramaters in XPlot mode
	SRS_REQ_45000	3.2.4.5	print parameter data
	SRS_REQ_64000	3.4.2	Mode of data displayed. Defined as : 1=physichal data; 2=electrical data;
	SRS_REQ_50000	3.2.5	Record electrical data in binary format and record engineering data in text format.
	IRS_REQ_21100	3.4.2	command from user for start or stop record electrical data
	IRS_REQ_21110	3.4.2	command from user for start or stop record engineering data
	IRS_REQ_21200	3.4.2	command from user for start or stop printing.
	IRS_REQ_21300	3.4.2	command from user for display elect or eng.
	IRS_REQ_21600	3.4.2	command from user to activate the running state
	IRS_REQ_21610	3.4.2	command from user to display parameter on the table mode.
	IRS_REQ_21620	3.4.2	command from user to display parameter on the graphic mode.
	IRS_REQ_21630	3.4.2	command from user to display parameter on the mixed mode.
IRS_REQ_21640	3.4.2	command from user to display parameter on the xplot mode.	
IRS_REQ_21700	3.4.2	command from user to deactivate running state	
System able to run on PC/AT	SRS_REQ_91000	3.9	target computer
System equiped with computer PC	SRS_REQ_93100	3.9	artist card
	SRS_REQ_93200	3.9	Dot matrix printer Epson LQ series
	SRS_REQ_93300	3.9	ARTISt cable
	SRS_REQ_93400	3.9	Hard disk
	SRS_REQ_93500	3.9	Operating System MS-DOS
Input data from OBDAS	SRS_REQ_94000	3.9	obdas

Table 14 : "Table requirement traceability"



**SOFTWARE REQUIREMENTS
SPECIFICATION**
for Airborne Real Time Instrumentation System

Document No.
EM/000/SRS/DD/003

Revision: 1

4 QUALIFICATION REQUIREMENTS

4.1 Qualification methods

The qualification methods to be used to ensure the Airborne Real Time Instrumentation System requirements of section three and five has been satisfied is as follows :

REQUIREMENT NAME	IDENTIFIER	SECTION 3 PARAGRAPH	QUALIFICATION	
			METHOD(S)*	LEVEL**
Initiate/Setup Program	SRS_REQ_11000	3.2.1.1	I	1
	SRS_REQ_54000	3.4.2	I	1
	SRS_REQ_55000	3.4.2	I	1
	SRS_REQ_56000	3.4.2	I	1
	SRS_REQ_57000	3.4.2	I	1
	SRS_REQ_59000	3.4.2	I	1
	IRS_REQ_41100	3.6.2	I	1
	SRS_REQ_12100	3.2.1.2.1	I	1
	SRS_REQ_12200	3.2.1.2.2	I	1
	IRS_REQ_41200	3.6.2	I	1
	IRS_REQ_22100	3.4.2	I	1
	SRS_REQ_13000	3.2.1.3	I	1
	SRS_REQ_13100	3.2.1.3.1	I	1
	IRS_REQ_22230	3.4.2	I	1
	SRS_REQ_59300	3.4.2	I	1
	SRS_REQ_13200	3.2.1.3.2	I	1
	IRS_REQ_22210	3.4.2	I	1
	SRS_REQ_59100	3.4.2	I	1
	SRS_REQ_13300	3.2.1.3.3	I	1
	IRS_REQ_22220	3.4.2	I	1
	SRS_REQ_59200	3.4.2	I	1
	SRS_REQ_13400	3.2.1.3.4	I	1
	IRS_REQ_22240	3.4.2	I	1
	SRS_REQ_59400	3.4.2	I	1
	IRS_REQ_22200	3.4.2	I	1
	SRS_REQ_14000	3.2.1.4	I	1
	IRS_REQ_12000	3.3.2	I	1
	SRS_REQ_14100	3.2.1.4.1	I	1
	SRS_REQ_14200	3.2.1.4.2	I	1
	SRS_REQ_14300	3.2.1.4.3	I	1
SRS_REQ_14400	3.2.1.4.4	I	1	
SRS_REQ_14500	3.2.1.4.5	I	1	
SRS_REQ_14600	3.2.1.4.6	I	1	



**SOFTWARE REQUIREMENTS
SPECIFICATION**
for Airborne Real Time Instrumentation System

Document No.
EM/000/SRS/DD/003

Revision: 1

cont'd

REQUIREMENT NAME	IDENTIFIER	SECTION 3 PARAGRAPH	QUALIFICATION	
			METHOD(S)*	LEVEL**
	SRS_REQ_65000	3.4.2	I	1
	SRS_REQ_56800	3.4.2	I	1
	SRS_REQ_15100	3.2.1.5	I	1
	IRS_REQ_41300	3.6.2	I	1
	IRS_REQ_22800	3.4.2	I	1
	SRS_REQ_76000	3.4.2	I	1
	SRS_REQ_16000	3.2.1.6	I	1
	SRS_REQ_16100	3.2.1.6.1	I	1
	SRS_REQ_16200	3.2.1.6.1	I	1
	IRS_REQ_22400	3.4.2	I	1
	SRS_REQ_74000	3.4.2	I	1
	SRS_REQ_75000	3.4.2	I	1
	SRS_REQ_16100	3.2.1.6.1	I	1
	IRS_REQ_32000	3.5.2	I	1
	SRS_REQ_16200	3.2.1.6.2	I	1
	IRS_REQ_21400	3.4.2	I	1
	IRS_REQ_21410	3.4.2	I	1
	IRS_REQ_21420	3.4.2	I	1
	IRS_REQ_21430	3.4.2	I	1
	IRS_REQ_21440	3.4.2	I	1
	IRS_REQ_21500	3.4.2	I	1
	IRS_REQ_21800	3.4.2	I	1
	IRS_REQ_21900	3.4.2	I	1
	IRS_REQ_22400	3.4.2	I	1
	IRS_REQ_22500	3.4.2	I	1
	IRS_REQ_22600	3.4.2	I	1
	IRS_REQ_22700	3.4.2	I	1
	IRS_REQ_23000	3.4.2	D,I	1
Collect Electrical Data from ACARD	SRS_REQ_20000	3.2.2	I	1
	IRS_REQ_11000	3.3.2	I	1
	SRS_REQ_21300	3.2.2.1	I	1
	IRS_REQ_21000	3.3.2	I	1
	SRS_REQ_73000	3.4.2	I	1
	SRS_REQ_21000	3.2.2.1	I	1
	SRS_REQ_67000	3.4.2	I	1
	SRS_REQ_68000	3.4.2	I	1
	SRS_REQ_22000	3.2.2.2	I	1
	SRS_REQ_70000	3.4.2	I	1
	SRS_REQ_23000	3.2.2.3	I	1
	SRS_REQ_69000	3.4.2	I	1
	SRS_REQ_24000	3.2.2.4	I	1
	SRS_REQ_71000	3.4.2	I	1



**SOFTWARE REQUIREMENTS
SPECIFICATION
for Airborne Real Time Instrumentation System**

**Document No.
EM/000/SRS/DD/003**

Revision: 1

cont'd

REQUIREMENT NAME	IDENTIFIER	SECTION 3 PARAGRAPH	QUALIFICATION	
			METHOD(S)*	LEVEL**
Translate to Engineering Data	SRS_REQ_30000	3.2.3	A	1
	SRS_REQ_31100	3.2.3.1	I	1
	SRS_REQ_31200	3.2.3.1	I	1
	SRS_REQ_56300	3.4	I	1
	SRS_REQ_56400	3.4	I	1
	SRS_REQ_56850	3.4	I	1
	SRS_REQ_34000	3.2.3.4	I	1
	SRS_REQ_66000	3.4	I	1
	SRS_REQ_67000	3.4	I	1
	SRS_REQ_35000	3.2.3.5	A	1
	SRS_REQ_36000	3.2.3.6	A	1
	SRS_REQ_37000	3.2.3.7	A	1
	SRS_REQ_38000	3.2.3.8	A	1
	SRS_REQ_56900	3.4	I	1
Show Electrical/Engineering Data & Save Electrical Data	SRS_REQ_41100	3.2.4.1	D	1
	SRS_REQ_42100	3.2.4.2	D	1
	SRS_REQ_43100	3.2.4.3	D	1
	SRS_REQ_44100	3.2.4.4	D	1
	SRS_REQ_45000	3.2.4.5	D	1
	IRS_REQ_32000	3.5.2	I	1
	SRS_REQ_50000	3.2.5	D,I	1
	SRS_REQ_51000	3.2.5.1	I	1
	SRS_REQ_51100	3.2.5.1	I	1
	SRS_REQ_52000	3.2.5.2	I	1
	IRS_REQ_21100	3.4.2	D,I	1
	IRS_REQ_21110	3.4.2	D,I	1
	IRS_REQ_21200	3.4.2	D,I	1
	IRS_REQ_21300	3.4.2	D,I	1
	IRS_REQ_21600	3.4.2	D,I	1
	IRS_REQ_21610	3.4.2	D,I	1
	IRS_REQ_21620	3.4.2	D,I	1
	IRS_REQ_21630	3.4.2	D,I	1
	IRS_REQ_21640	3.4.2	D,I	1
IRS_REQ_21700	3.4.2	D,I	1	
Computer target	SRS_REQ_91000	3.9	I	4
Used language	SRS_REQ_92000	3.9	I	3
Used Hardware	SRS_REQ_93100, SRS_REQ_93200, SRS_REQ_93300, SRS_REQ_93400, SRS_REQ_93500	3.9	I	4
	SRS_REQ_94000	3.9	I	4

***Qualification Method**
A – Analysis
D – Demonstration
I – Inspection

****Qualification Level**
1 – Configuration Item
2 – System Integration
3 – System
4 – System Installation

Table 15 : "Qualification Method"



**SOFTWARE REQUIREMENTS
SPECIFICATION**
for Airborne Real Time Instrumentation System

Document No.
EM/000/SRS/DD/003

Revision: 1

4.2 Special qualification requirements

Not Applicable



**SOFTWARE REQUIREMENTS
SPECIFICATION**
for Airborne Real Time Instrumentation System

Document No.
EM/000/SRS/DD/003

Revision: 1

5 PREPARATION FOR DELIVERY

The CSCI documents will be delivered in hardcopy (paper format).
Executable files may be delivered within floppy disk 3.5".



**SOFTWARE REQUIREMENTS
SPECIFICATION
for Airborne Real Time Instrumentation System**

Document No.
EM/000/SRS/DD/003

Revision: 1

6 NOTES

Used acronyms and abbreviations:

- ACARD : ARTISt Card
- APRINTER : ARTISt Printer
- ARINC : Aeronautical Radio Incorporated
- ARTISt : Airborne Real Time Instrumentation System
- CCD : Control Context Diagram (SA/RT model element)
- CFD : Control Flow Diagram (SA/RT model element)
- CPU : Central Processing Unit
- DCD : Data Context Diagram
- DFD : Data Flow Diagram
- DMS : Disk Management System
- CSCI : Computer Software Configuration Item
- DOD : Department of Defense
- EM : Electronic Center and Measurement System
- IPTN : Industri Pesawat Terbang Nusantara
- IRS : Interface Requirement Specification
- MMIMS : Man Machine Interface Management System
- NDS : Non Developmental Software
- OBDAS : On Board Data acquisition System
- PC : Personal Computer
- PCM : Pulse Code Modulation
- PSPEC : Process Specification
- RAM : Random Access Memory
- RTCA : Radio Technical Commission for Aeronautics
- RTSE : Real Time Software Engineering
- SA/RT : Structured Analysis for Real Time
- SRS : Software Requirements Specification
- STRp : Software Test Report
- TODD : Technique for Object Oriented Design